

# B614

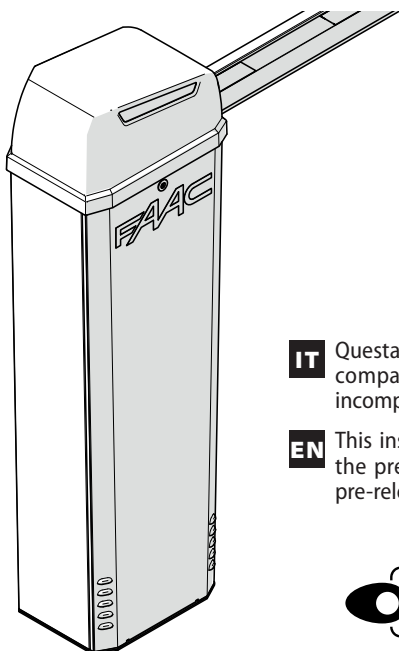

**IT** Questa istruzione è una bozza preliminare destinata ad accompagnare il prodotto di pre-serie. Alcune parti sono incomplete o in versione non definitiva.

**EN** This instruction is a preliminary draft meant to accompany the pre-series product. Some parts are incomplete or in pre-release version.



# FAAC

Translation of the original instructions



FAAC S.p.A. Soc. Unipersonale  
Via Calari, 10 - 40069 Zola Predosa BOLOGNA - ITALY  
Tel. +39 051 61724 - Fax +39 051 758518  
www.faac.it - www.faacgroup.com

© Copyright FAAC S.p.A. dal 2017. Tutti i diritti riservati.

Nessuna parte di questo manuale può essere riprodotta, archiviata, distribuita a terzi né altrimenti copiata, in qualsiasi formato e con qualsiasi mezzo, sia esso elettronico, meccanico o tramite fotocopia, senza il preventivo consenso scritto di FAAC S.p.A.

Tutti i nomi e i marchi citati sono di proprietà dei rispettivi fabbricanti.

I clienti possono effettuare copie per esclusivo utilizzo proprio.

Questo manuale è stato pubblicato nel 2017.

© Copyright FAAC S.p.A. from 2017. All rights reserved.

No part of this manual may be reproduced, archived, distributed to third parties nor copied in any other way, in any format and with any means, be it electronic, mechanical or by photocopying, without prior written authorisation by FAAC S.p.A.

All names and trademarks mentioned are the property of their respective manufacturers.

Customers may make copies exclusively for their own use.

This manual was published in 2017.

© Copyright FAAC S.p.A. depuis 2017. Tous droits réservés.

Aucune partie de ce manuel ne peut être reproduite, archivée ou distribuée à des tiers ni copiée, sous tout format et avec tout moyen, qu'il soit électronique, mécanique ou par photocopie, sans le consentement écrit préalable de FAAC S.p.A.

Tous les noms et les marques cités sont la propriété de leurs fabricants respectifs.

Les clients peuvent faire des copies pour leur usage exclusif.

Ce manuel a été publié en 2017.

© Copyright FAAC S.p.A. ab dem 2017. Alle Rechte vorbehalten.

Kein Teil dieses Handbuchs darf reproduziert, gespeichert, an Dritte weitergegeben oder sonst auf eine beliebige Art in einem beliebigen Format und mit beliebigen Mitteln kopiert werden, weder mit elektronischen, noch mechanischen oder durch Fotokopieren, ohne die Genehmigung von FAAC S.p.A.

Alle erwähnten Namen und Marken sind Eigentum der jeweiligen Hersteller.

Die Kunden dürfen nur für den Eigengebrauch Kopien anfertigen.

Dieses Handbuch wurde 2017 veröffentlicht.

© Copyright FAAC S.p.A. del 2017. Todos los derechos están reservados.

No puede reproducirse, archivar, distribuirse a terceros ni copiarse de ningún modo, ninguna parte de este manual, con medios mecánicos o mediante fotocopia, sin el permiso previo por escrito de FAAC S.p.A.

Todos los nombre y las marcas citadas son de propiedad de los respectivos fabricantes.

Los clientes pueden realizar copias para su uso exclusivo.

Este manual se ha publicado en 2017.

© Copyright FAAC S.p.A. van 2017. Alle rechten voorbehouden.

Niets uit deze handleiding mag gereproduceerd, gearchiveerd, aan derden openbaar gemaakt of op andere wijze gekopieerd worden, in om het even welke vorm en met geen enkel middel, noch elektronisch, mechanisch of via fotokopiëren, zonder schriftelijke toestemming vooraf van FAAC S.p.A.

Alle vermelde namen en merken zijn eigendom van de respectievelijke fabrikanten.

De klanten mogen kopieën maken die enkel voor eigen gebruik bestemd zijn.

Dez handleiding werd in 2017 gepubliceerd.

**EU DECLARATION OF CONFORMITY**

The Manufacturer

**Company name:** FAAC S.p.A. Soc. Unipersonale  
**Address:** Via Calari, 10 - 40069 Zola Predosa BOLOGNA -ITALY

hereby declares under its own exclusive liability that the following product:

**Description:** Barrier  
**Model:** B614

complies with the following applicable EU legislations:

2014/30/EU  
 2011/65/EU

Furthermore, the following harmonised standards have been applied:

EN 61000-6-2:2005  
 EN 61000-6-3:2007 + A:2011

Bologna, Italy 20-10-2016 CEO

**DECLARATION OF INCORPORATION FOR PARTLY COMPLETED MACHINERY**

(2006/42/EC ANNEX II P.1, B)

Manufacturer and person authorised to prepare the relevant technical documentation

**Company name:** FAAC S.p.A. Soc. Unipersonale  
**Address:** Via Calari, 10 - 40069 Zola Predosa BOLOGNA -ITALY

hereby declares that for the partly completed machinery:

**Description:** Barrier  
**Model:** B614

The essential requirements of the Machinery Directive 2006/42/EC (including all applicable amendments) that have been applied and fulfilled are as follows:

1.1.2; 1.1.3; 1.1.5; 1.2.1; 1.2.3; 1.2.5; 1.2.6; 1.3.1; 1.3.2; 1.3.4; 1.3.6; 1.3.8.1; 1.3.9; 1.4.1; 1.4.2.1; 1.5.1;  
 1.5.2; 1.5.3 1.5.5; 1.5.6; 1.5.7; 1.5.8; 1.5.10; 1.5.11; 1.5.13; 1.6.1; 1.6.4; 1.7.3; 1.7.4.1; 1.7.4.2; 1.7.4.3

and that the relevant technical documentation has been compiled in compliance with part B of Annex VII.

Furthermore, the following harmonised standards have been applied:

EN60335-1: 2012 + A11:2014  
 EN12100:2010  
 EN13849-1:2015 CAT 2 PL "c"  
 EN13849-2:2012

Other standards applied:



EN 12453:2000

And also undertakes to transmit, in response to a reasoned request by the national authorities, relevant information on the partly completed machinery by mail or e-mail.

Finally, the manufacturer declares that the above-mentioned partly completed machinery must not be put into service until the final machine in which it is to be incorporated has been declared compliant with the requirements of the above-mentioned Machinery Directive 2006/42/EC.

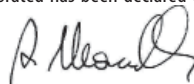















Bologna, Italy 20-10-2016 CEO



EU Declaration of conformity.....	1	5.10 Closing the door .....	29
Declaration of incorporation for partly completed machinery		5.11 Closing the upper lid.....	30
<b>1. INTRODUCTION TO THIS INSTRUCTIONS MANUAL.....</b>	<b>4</b>	<b>6. INSTALLING OPTIONAL FEATURES .....</b>	<b>31</b>
1.1 Meaning of the symbols used.....	4	6.1 Personalised key release.....	31
<b>2. SAFETY RECOMMENDATIONS.....</b>	<b>6</b>	<b>7. ELECTRONIC INSTALLATION .....</b>	<b>32</b>
2.1 Installer safety .....	6	7.1 Board E614 .....	32
2.2 Transport and storage .....	7	Components .....	32
2.3 Unpacking and handling .....	8	7.2 Connections.....	34
2.4 Disposal of the product.....	8	Control devices.....	34
<b>3. B614.....</b>	<b>9</b>	External loops.....	35
3.1 Intended use .....	9	Bus devices.....	35
3.2 Limitations of use.....	9	OUT outputs.....	35
3.3 Unauthorised use .....	9	24 V  flashing light .....	35
3.4 Emergency use.....	10	Motor.....	35
3.5 Product identification.....	10	Encoder.....	35
3.6 Technical specifications.....	10	Beam lights .....	36
3.7 Manual operation .....	11	Integrated flashing light .....	36
Release procedure .....	11	Battery XBAT 24 .....	36
Operation restoration.....	11	Radio module XF.....	36
3.8 Component identification .....	12	Mains supply and earthing .....	36
3.9 Installation components.....	13	<b>8. START-UP .....</b>	<b>37</b>
3.10 Optional accessories.....	13	8.1 Programming.....	37
<b>4. INSTALLATION REQUIREMENTS .....</b>	<b>14</b>	Basic programming.....	37
4.1 Mechanical requirements.....	14	Advanced programming .....	38
4.2 Electrical system.....	15	8.2 Operating logics.....	41
4.3 Example System.....	16	EP - Semi-automatic step by step.....	41
<b>5. MECHANICAL INSTALLATION .....</b>	<b>17</b>	FI - Automatic.....	41
5.1 Tools required .....	17	FIP - Automatic step-by-step .....	41
5.2 Placing the foundation plate .....	18	b - Semi-automatic b .....	41
5.3 Installing the barrier body .....	19	bC - Semiautomatic b on opening/ person present C on closure.....	41
Fixing the cables inside the barrier.....	20	C - Dead-man .....	41
5.4 Fitting the beam.....	21	P- Carpark .....	41
Preparing the balancer .....	21	8.3 SET-UP.....	42
Rectangular beam .....	21	<b>9. PUTTING INTO SERVICE .....</b>	<b>43</b>
Round beam.....	23	9.1 Final checks .....	43
5.5 Fitting the spring.....	25	9.2 Final operations .....	43
Tie rod .....	25	<b>10. ACCESSORIES .....</b>	<b>44</b>
Single spring .....	26	10.1 24V FLASHING LIGHT  .....	44
Double spring.....	26	10.2 Emergency battery XBAT 24.....	44
5.6 Accessories on the beam .....	27	10.3 Radio module XF .....	45
5.7 Balancing the beam .....	27	SLH/SLH LR - Memorising the first remote control.....	45
5.8 Limit switch adjustment.....	28	SLH/SLH LR - Memorising other remote controls .....	45
5.9 Earthing the door .....	29	LC/RC - Memorising the first remote control .....	45

LC/RC - Remote code memorisation procedure .....	45	12.4 Automation system status check .....	53
DS - Memorising remote controls .....	46	12.5 Check firmware version .....	53
Deleting remote controls from memory .....	46	12.6 Check of the registered BUS 2easy devices .....	53
10.4 BUS 2easy devices .....	47	12.7 Maintenance request - cycle counter .....	53
Connection .....	47	<b>13. MAINTENANCE .....</b>	<b>54</b>
BUS 2easy photocells .....	47	13.1 Routine maintenance .....	54
Control devices .....	47	13.2 Spring replacement .....	55
BUS 2easy device registration .....	48	13.3 Replacement of the electromechanical actuator .....	55
10.5 Round beam light kit .....	49	13.4 Fuse replacement .....	56
10.6 Integrated flashing light .....	49	13.5 Operational problems .....	56
10.7 Beam joint kit .....	49	<b>14. INSTRUCTIONS FOR USE .....</b>	<b>57</b>
10.8 Hedge .....	50	14.1 Safety recommendations .....	57
10.9 Foot .....	50	14.2 Emergency use .....	57
10.10 Fork .....	50	14.3 Manual operation .....	58
<b>11. MASTER-SLAVE .....</b>	<b>51</b>	Release procedure .....	58
Connection .....	51	Operation restoration .....	58
Slave barrier configuration .....	52		
<b>12. DIAGNOSTICS .....</b>	<b>53</b>		
12.1 LEDs check .....	53		
12.2 Direction of movement check .....	53		
12.3 Encoder operation check .....	53		

**TABLES**

 <b>1</b> Symbols: notes and warnings on the instructions .....	4	 <b>10</b> Advanced programming .....	39
 <b>2</b> Symbols: safety signs (EN ISO 7010) .....	5	 <b>11</b> Orienting the photocells .....	47
 <b>3</b> Symbols: personal protective equipment .....	5	 <b>12</b> Addressing control devices .....	48
 <b>4</b> Symbols: markings on packaging .....	7	 <b>13</b> Routine maintenance .....	54
 <b>5</b> Symbols: markings on product .....	10	 <b>14</b> Periodic replacements .....	55
 <b>6</b> Technical data .....	11	 <b>15</b> Troubleshooting .....	56
 <b>7</b> Board technical data sheet E614 .....	32	 <b>16</b> Rectangular beam balancing .....	60
 <b>8</b> Basic programming .....	38	 <b>17</b> Round beam S balancing .....	60
 <b>9</b> Speed default .....	39		

**ADDENDUM**

 <b>1</b> Foundation for barrier in maximum configuration .....	59
 <b>2</b> Balancing system .....	60

1. INTRODUCTION TO THIS INSTRUCTIONS MANUAL

This manual provides the correct procedures and requirements for installing B614 and maintaining it in a safe condition.

When drafting the manual, the results of the risk assessment conducted by FAAC S.p.A. on the entire product life cycle have been taken into account in order to implement effective risk reduction measures. The following stages of the life cycle of the product have been considered:

- Delivery/handling
- Assembly and installation
- Set-up and commissioning
- Operation
- Maintenance/troubleshooting
- Disposal at the end of the product's life cycle

Risks arising from installation and using the product have been taken into consideration; these include:

- Risks for the installation/maintenance technician (technical personnel)
- Risks for the user of the automation system
- Risks to product integrity (damage)

In Europe, the automation of a barrier falls under the Machinery Directive 2006/42/EC and the corresponding harmonised standards. Anyone automating a barrier (new or existing) is classified as the Manufacturer of the Machine. They are therefore required by law, among other things, to carry out a risk analysis of the machine (automatic barrier in its entirety) and take protective measures to fulfil the essential safety requirements specified in Annex I of the Machinery Directive.

FAAC S.p.A. recommends that you always comply with standards EN 12453 and EN 12445 and in particular that you adopt the safety criteria and devices indicated in these standards, without exception, including the dead-man function.

This manual also contains general information and guidelines, which are purely illustrative and not exhaustive, in order to facilitate the activities carried out by the Manufacturer of the Machine in all respects with regard to carrying out the risk analysis and drafting the instructions for use and maintenance of the machine. It should be clearly understood that FAAC S.p.A. accepts no liability for the reliability and/ or completeness of the above instructions. As such, the manufacturer of the machine must carry out all the activities required by the Machinery Directive and the corresponding harmonised standards on the basis of the actual condition of the locations and structures where the product B614 will be installed, prior to commissioning the machine. These activities include the analysis of all the risks associated with the machine and subsequent implementation of all safety measures intended to fulfil the essential safety requirements.

This manual contains references to European standards. The automation of a barrier must fully comply with any laws, standards and regulations applicable in the country where installation will take place.

 Unless otherwise specified, the measurements provided in the instructions are in mm.

1.1 MEANING OF THE SYMBOLS USED

 1 Symbols: notes and warnings on the instructions

 WARNING ELECTRIC SHOCK HAZARD - The operation or stage described must be performed following the instructions supplied and applicable safety regulations

 WARNING, PERSONAL INJURY HAZARD OR RISK OF DAMAGE TO COMPONENTS - The operation or stage described must be performed following the supplied instructions and applicable safety regulations

 WARNING - Details and specifications which must be respected in order to ensure that the system operates correctly

 RECYCLING and DISPOSAL - Components and structural materials, batteries and electronic components must not be disposed of together with household waste. They must be taken to authorised disposal and recycling centres

 For manual lifting, there should be 1 person for every 20 kg to be lifted

 PAGE E.g.: 6 see Page 6



 FIGURE E.g.: 1-3 see Figure 1 - item 3

 TABLE E.g.: 1 see Table 1

§ CHAPTER/SECTION E.g.: §1.1 see section 1.1

 APPENDIX E.g.: 1 see Appendix 1

 Automatic operation - automation system locked

 Manual operation - automation system unlocked

**2** Symbols: safety signs (EN ISO 7010)

- 

GENERAL HAZARD - Risk of personal burns or damage to the parts
- 

RISK OF ELECTRIC SHOCK - Risk of electric shock from live parts
- 

RISK OF CRUSHING, MUSCULAR - SKELETAL PROBLEMS - Risk of crushing or muscular and skeletal injury when lifting heavy loads
- 

RISK OF BURNS OR BURNING - Risk of burns or burning because of very hot parts.
- 

RISK OF CRUSHING - Risk of crushing hands/feet due to heavy parts
- 

RISK OF CRUSHING HANDS - Risk of crushing hands due to moving parts
- 

RISK OF CUTS/AMPUTATION/SPEARING - Risk of cuts due to sharp parts or the use of sharp implements (drill)
- 

RISK OF SHEARING - Risk of shearing due to moving parts
- 

RISK OF IMPACT/CRUSHING/SHEARING - Risk of impact, crushing or shearing due to moving parts
- 

RISK OF OBJECTS FALLING FROM ABOVE - Risk of impact due to objects falling
- 

RISK OF TRIPPING - Risk of tripping due to raised sections above 5 mm.
- 

RISKS FROM BATTERIES AT THE END OF THEIR LIVES - Risk to the environment and health posed by batteries at the end of their lives due to fluid escaping
- 

RISK OF FORKLIFT TRUCK IMPACT - Risk of being hit by or colliding with forklift trucks

**3** Symbols: personal protective equipment  
 Personal protective equipment must be worn to protect against hazards (e.g. crushing, cutting, shearing etc.):

- 

Obligation to wear head protection helmet
- 

Obligation to wear safety footwear
- 

Obligation to wear mask/goggles to protect the eyes from the risk of fragments due to the use of drill or welder
- 

Obligation to wear work gloves
- 

Obligation to wear ear protectors
- 

Obligatory use of work clothes without parts that could become caught in moving parts

**2. SAFETY RECOMMENDATIONS**

This product is placed onto the market as “partly completed machinery”, therefore it cannot be commissioned until the machine in which it will be incorporated has been identified and declared to conform to the Machinery Directive 2006/42/EC by the actual Manufacturer.



Incorrect installation and/or incorrect use of the product might cause serious harm to people. Read and comply with all the instructions before starting any activity on the product. Keep these instructions for future reference.

Perform installation and other activities adhering to the sequences provided in the instructions manual.

Always comply with all the requirements contained in the instructions and warning tables at the beginning of the paragraphs. Always comply with the safety recommendations.

Only the installer and/or maintenance technician is authorised to work on the automation components. Do not modify the original components in any way.

Close off the work site (even temporarily) and prevent access/transit. EC countries must comply with the legislation that transposes the European Construction Site Directive 92/57/EC.

The installer is responsible for the installation/testing of the automation and for completing the Register of the system.

The installer must prove or declare to possess technical and professional proficiency to perform installation, testing and maintenance activities according to the requirements in these instructions.

**2.1 INSTALLER SAFETY**

Installation activities require special work conditions to reduce to the minimum the risks of accidents and serious damage. Furthermore, the suitable precautions must be taken to prevent risks of injury to persons or damage.



The installer must be in good physical and mental condition, aware of and responsible for the hazards that may be generated when using the product.

The work area must be kept tidy and must not be left unattended.

Do not wear clothes or accessories (scarves, bracelets, etc.) that may get caught in moving parts.

Always wear the personal protective equipment recommended for the type of activity to be carried out.

The required level of workplace lighting must be equal to at least 200 lux.

Operate CE marked machinery and equipment in compliance with the manufacturer’s instructions. Use work instruments in good conditions.

Use the transport and lifting equipment recommended in the instructions manual.

Use safety-compliant portable ladders of adequate size, fitted with anti-slip devices at the top and bottom, equipped with retainer hooks.



## 2.2 TRANSPORT AND STORAGE

 Follow the instructions on the packaging during handling. Two people must move the package. Use the HANDLES.

 4 Symbols: markings on packaging

 Read the instructions

 This way up indication: do not turn upside down

 Store away from water and humidity

 Maximum number of stacked pallets

 Maximum number of stacked packages

 Humidity percentage for storage

 Storage temperature

 CE marking

 Wear work gloves

 Wear safety footwear

 20 kg is the MAX weight one person can lift

Kg \_\_\_\_\_ Weight of the package

### PALLETISED SUPPLY

#### RISKS



#### PERSONAL PROTECTIVE EQUIPMENT

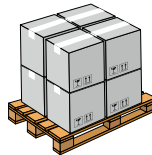

 Use a forklift or pallet truck, following safety regulations to avoid the risk of impacts or collisions.

### SINGLE PACKAGE

#### RISKS



#### PERSONAL PROTECTIVE EQUIPMENT



 For manual lifting, there should be 1 person for every 20 kg to be lifted.

### STORAGE

Keep the product in its original packaging, in a dry place indoors, away from direct sunlight, dust and corrosive substances. Protect from mechanical stresses. If storing for longer than 3 months, periodically check the condition of the components and the packaging.

- Storage temperature: from 5 °C to 30 °C.
- Storage humidity: from 30% to 70%.

## 2.3 UNPACKING AND HANDLING

### RISKS



### PERSONAL PROTECTIVE EQUIPMENT



For manual lifting, there should be 1 person for every 20 kg to be lifted.

Two people must move the package. Use the handles.

Never manage the barrier by holding the board holder.

- Carefully set the package down on the ground.
- Cut the packaging to open it right up and remove all the packaging material.
- Stand the barrier on the base.

Check that all components are present and intact 1.

- Dispose of the packaging materials.

The packaging materials (plastic, polystyrene, etc.) must not be left within reach of children as they are potential sources of danger.



When you have finished with them, dispose of the packaging in the appropriate containers, as per applicable waste disposal regulations.

## 2.4 DISPOSAL OF THE PRODUCT

After dismantling the product, dispose of it in compliance with Standards in force.



The constructive components and materials, batteries and electronic components must not be disposed of with household waste but delivered to authorised disposal and recycling facilities.

1 Barrier body B614

2 Upper lid

3 Installation accessories

4 Instruction manual

5 Risk signalling

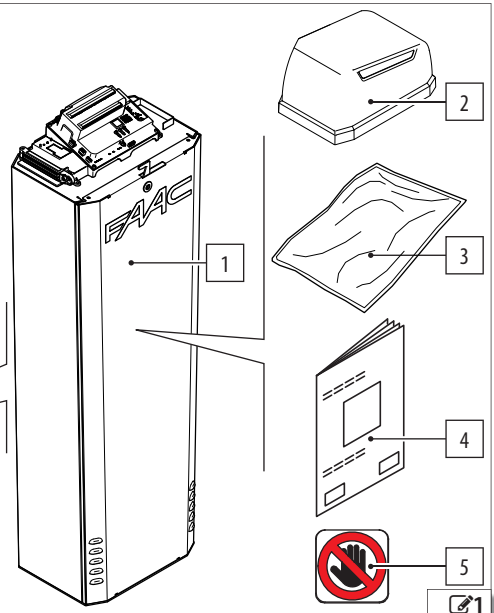
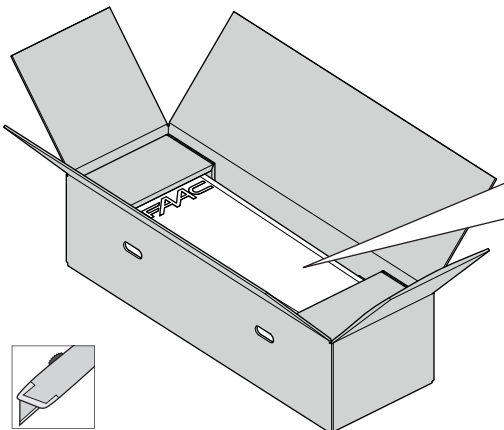

### 3. B614

#### 3.1 INTENDED USE

The B614 barriers are designed for vehicular access control in residential buildings/apartment complexes. To move the beam manually, follow the instructions for manual functioning.



Any other use that is not expressly specified in these instructions is prohibited and could affect the integrity of the product and/or represent a source of danger.

#### 3.2 LIMITATIONS OF USE

Respect the limits of usage frequency indicated in the technical specifications.

B614 requires the use of a specific FAAC beam that conforms with the dimensions indicated in this manual. Only FAAC accessories indicated in this manual may be fitted to the beam.

B614 requires the use of a FAAC spring that is adequate for counterbalancing the weight of the beam and relative accessories

The presence of even occasional environmental phenomena such as ice, snow or strong wind may compromise the proper operation of the automation, the integrity of the components and become a potential source of danger (see section 5 Use in an emergency). The limit of use of B614 in the wind is grade 10 on the Beaufort Scale (max. speed: 102 km/h). B614 it has not been designed as a system to keep intruders out.

Creating the automation requires the installation of the necessary safety devices chosen by the installation engineer through the proper checks on the installation site.

The installation must be visible in daylight and at night. If it is not, it is necessary to install whatever is necessary to make the fixed and moving parts visible (light kit on the beam).

The barriers with exclusively vehicle access control must fitted with suitable visible signs prohibiting foot traffic. A separate route for foot traffic outside the range of the beam must be provided and properly indicated. If the foot traffic cannot be excluded, the barrier enters within the scope of the EN 12453 and EN 12445 standards.

#### 3.3 UNAUTHORISED USE

- Uses other than the intended use are prohibited.
- It is prohibited to install the automation system outside of the limits specified in the Technical Data

and Installation Requirements sections.

- It is forbidden to use B614 in a constructional configuration other than the one provided by the manufacturer.
- No component part of the product may be modified.
- It is prohibited to install the automation system on escape routes.
- It is prohibited to install the automation system in environments in which there is a risk of explosion and/or fire: the presence of flammable gases or fumes is a serious safety hazard (the product is not 94/9/EC ATEX certified).
- It is prohibited to power the system with energy sources other than those specified.
- It is prohibited to integrate commercial systems and/or equipment other than those specified, or use them for purposes not intended and authorised by their respective manufacturers.
- Do not allow water jets of any type or size to come into direct contact with the actuator.
- Do not expose the actuator to corrosive chemicals or atmospheric agents.
- Do not expose the barrier to direct jets of water of any type and size.
- Do not expose the barrier to aggressive chemical or environmental agents.
- The barrier may not be used to move moving parts other than the beams produced by FAAC specified in this manual.
- Use to control pedestrian access, bicycle traffic and the passage of animals is prohibited.
- Use of the barrier at level crossings is prohibited.
- Use of the barrier on public thoroughfares is prohibited.
- It is prohibited to use and/or install accessories which have not been specifically approved by FAAC S.p.A.
- It is prohibited to use the automation system before performing commissioning.
- It is prohibited to use the automation system in the presence of faults which could compromise safety.
- It is prohibited to use the automation system with the fixed and/or mobile guards removed or altered.
- Do not use the automation system unless the area of operation is free of persons, animals or objects.
- Do not enter/remain in the area of operation of the automation system while it is moving.
- Do not try to prevent the movement of the automation system.
- Do not climb on, hold onto or let yourself be pulled by the leaf. Do not climb onto the actuator.
- Do not climb or catch on to the beam or lift yourself up on it. Do not climb on the barrier cabinet.

- Do not allow children to approach or play in the area of operation of the automation system.
- Do not allow the control devices to be used by anyone who is not specifically authorised and trained to do so.
- Do not allow the control devices to be used by children or persons with mental and physical deficiencies unless they are supervised by an adult who is responsible for their safety.

 During manual handling, accompany the beam slowly for the entire stroke. Do not let the beam travel freely.

### 3.4 EMERGENCY USE

In any case the beam is not behaving properly, in emergencies or if there is a fault, turn off the electricity supply to the automation system and disconnect the buffer batteries if there are any. If the conditions exist for the manual movement of the beam safely, use the MANUAL FUNCTION; otherwise keep the automation out of order until the repair or restoration.

In the case of a breakdown, the automation system must be reset/repared exclusively by the INSTALLER/MAINTENANCE TECHNICIAN.

### 3.5 PRODUCT IDENTIFICATION

The product is identified by the plate .

### 3.6 TECHNICAL SPECIFICATIONS

B614 it is an electromechanical barrier with a E614 electronic board fitted. B614 it must be installed on the specific foundation plate and cemented onto a plinth

**RH/LH barrier** B614 makes it possible to build a right hand or left hand barrier without modifying the barrier body.

-  The barrier will be installed with the door towards the inside of the property.
- The barrier is defined by observing it from the door side:
- **RH barrier** (right): the beam closes towards the right (in a clockwise direction)
  - **LH barrier** (left): the beam closes towards the left (in an anticlockwise direction)

**Irreversible system** To allow manual operation, the release manoeuvre must be performed.

**Encoder** B614 is fitted with an encoder. The encoder constantly detects the precise position of the beam and makes it possible to manage the end of stroke and slowing downs stored with the set up.

**Anticrushing operation** The encoder allows the board to create the anticrushing feature:

- the recognition of an obstacle during closure causes the manoeuvre to be reversed
- the recognition of an obstacle during opening

causes the beam to stop.

**Adjustable end of stroke** The barrier is fitted with an adjustable mechanical end of opening and closing stroke feature.

**Equipment** A rectangular or round beam can be installed. The components necessary for the installation and the optional equipment are listed in the dedicated sections.

**Balancing system** The balancing spring must be used FAAC. The single or double spring depending on the length and configuration of the installed beam must be fitted in the definite fitting positions.

 The balancing system is important for safety reasons to ensure the stability and control of the beam during movement and keep it operating properly over time.

**Master-Slave Configuration** To install two barriers that open in opposite directions it is necessary to create the Master-Slave configuration.

 5 Symbols: markings on product





Risk of crushing between the moving parts. Present on the balancer

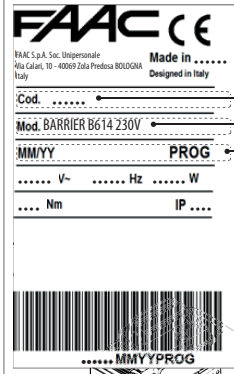

Risk of cutting, crushing or shearing of fingers or a hand between the beam and the barrier body. It must be placed on the trunk by the installation engineer.

"DANGER OF AUTOMATIC MOVEMENT" (not supplied) It must be placed on the trunk by the installation engineer.



**FAAC** 

FAAC S.p.A. Soc. Unipersonale  
Via Castel, 10 - 40069 Zola Predosa BOLOGNA  
Italy **Made in .....**  
Designed in Italy

Cod. ....

Mod. BARRIER B614 230V

MM/YY **PROG**

..... V~ ..... Hz ..... W

... Nm IP ....

..... MMYYPROG

— Sale code

— Product name

— IDENTIFICATION NUMBER

Month/year of production + progressive number for the month of production

Example:

0116                      0001

made in.                      progressive:

January 2017                      0001

6 Technical data

	B614 220-240 V ~	B614 115 V ~
Supply voltage	220-240 V~ 50/60 Hz	115V~ +/-10% 50/60 Hz
Electric motor	24V ==	24V ==
Max power	165 W	165 W
Max torque	300 Nm - 63 Nm (Breakaway - 45°)	300 Nm - 63 Nm (Breakaway - 45°)
Opening time (80°)		
- beam 3 m	< 2 sec.	< 2 sec.
- beam 5 m	< 3 sec.	< 3 sec.
Use frequency	100 %	100 %
Ambient operating temperature	-20 °C ... +55 °C	-20 °C ... +55 °C
Ingress protection	IP 55	IP 55
Dimensions (L x D x H)	247 x 357 x 1163 mm	247 x 357 x 1163 mm
Weight	40 kg	40 kg

Base plate FAAC	
Dimensions (L x H)	230 x 305 mm

Beam FAAC	Beam length
Rectangular beam	2.00 ... 4.85 m max
Round beam	2.00 ... 5.20 m max

3.7 MANUAL OPERATION



- Performing the release manoeuvre when there is no electrical power.
- Performing the release manoeuvre only when the beam is at a standstill.
- During manual handling, accompany the beam slowly for the entire stroke. Do not let the beam travel freely.
- Do not leave the barrier unblocked: after carrying out the manual movement, restore automatic operation.

RELEASE PROCEDURE



1.  Open the lock cover. Insert the key and turn it once anticlockwise until it stops (1).
2. Move the automation manually.
3. Restore the operation

OPERATION RESTORATION



1.  Insert the key and turn it twice clockwise until it stops (2).
2. Check that manual movement is inhibited.
3. Remove the key and close the cover

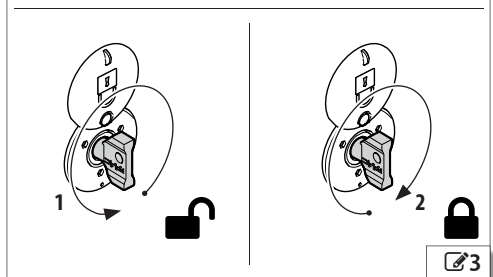
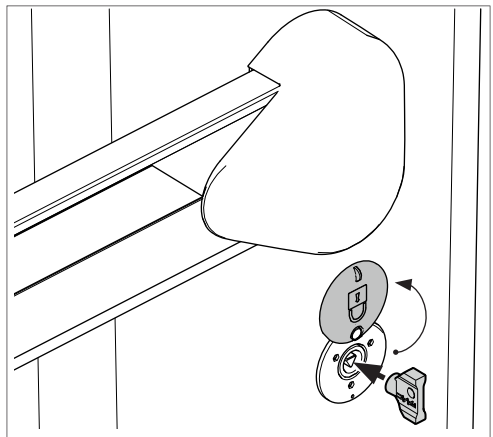

## 3.8 COMPONENT IDENTIFICATION

Standard equipment on the barrier body (☑4):

- 1 Bearing trunk
- 2 Drive shaft
- 3 Beam release device (triangular key)
- 4 Upper lid
- 5 Door with lock
- 6 Control board E614
- 7 Control board cover E614
- 8 Balancer/ upper spring fixing
- 9 Electromechanical actuator with Encoder
- 10 Slot for lower spring fixing
- 11 Limit switch

B614 beam side

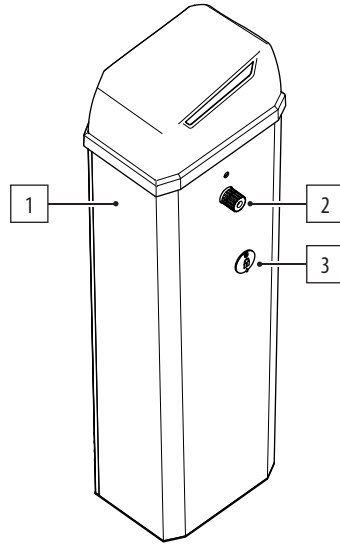

B614 door side

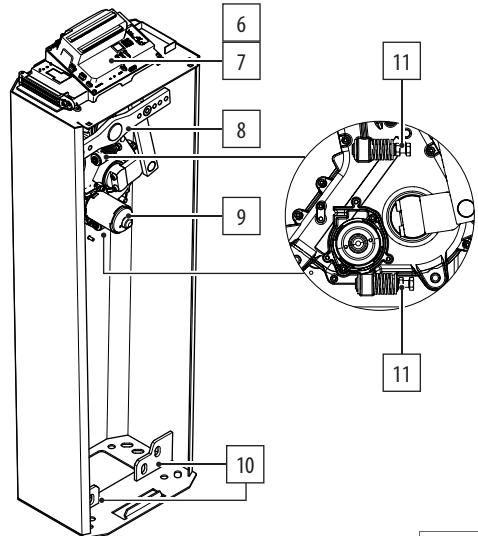
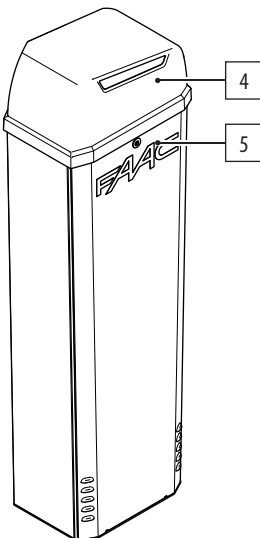

### 3.9 INSTALLATION COMPONENTS

The installation requires the following FAAC components supplied separately (☞5):

- 1 Base plate
- 2 Rectangular or round beam (the reflecting paper for round beam are supplied separately)
- 3 Fixing pocket for the installed beam (rectangular or round)
- 4 Single or double balancing spring

### 3.10 OPTIONAL ACCESSORIES

For the FAAC accessories for B614 see chapter § 10.

1 Base plate

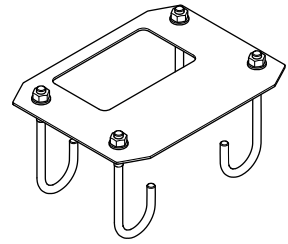

2 Rectangular beam

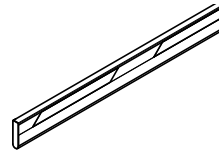

Round beam

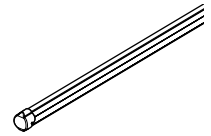

3 Pocket for rectangular beam

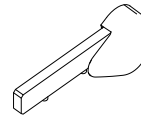

Pocket for round beam

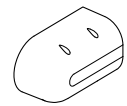

Adhesive reflectors for round beam



4 Single spring

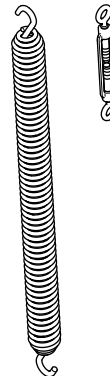

Double spring

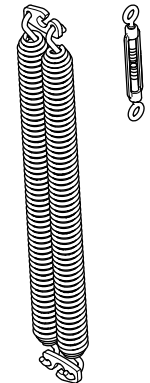

## 4. INSTALLATION REQUIREMENTS

### 4.1 MECHANICAL REQUIREMENTS

The mechanical structural components must comply with the requirements of the EN 12604:2002 and EN 12605:2001 standards.

Before installing the automation system, the suitability of the mechanical requirements must be established, and the necessary work to reach them performed.

The essential mechanical requirements are as follows:



Firm ground to support the weight of the barrier with flat, horizontal paving. There must be no chance of water accumulating in the installation area.

The presence of enough working space needed for the installation manoeuvres and subsequent maintenance operations bearing in mind the opening of the service door and the positioning/removal of the box and any other elements.

The thresholds and protrusions of the paving must be appropriately shaped in order to prevent the risk of sliding or slipping.

Absence of fixed or mobile obstacles to the movement of the beam (e.g.: branches, overhead cables, ceilings).

If the installation area presents the possibility of vehicle impact provided adequate protective structures to protect the barrier body.

The presence of an unimpeded safety area between the walls (or other fixed element) and the end of the beam that is adequate protection against the risk of crushing/trapping someone.

Suitable safety devices must be installed between the fixed and moving parts to prevent hands from being crushed.

For the minimum dimensions to prevent the crushing of body parts, refer to standard EN 349.

For the safety distances required to prevent danger zones being reached, refer to ISO 13857.

For the specifics relative to the creation of detection coils, refer to the relative instructions.

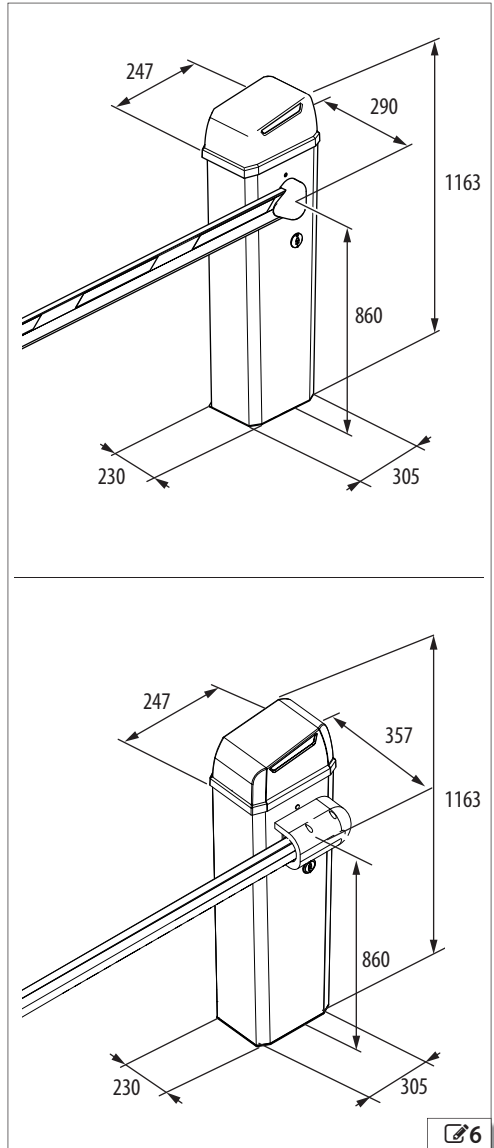



## 4.2 ELECTRICAL SYSTEM



Always shut off the power supply before performing any work. If the disconnect switch is not in view, apply a warning sign stating "WARNING - Maintenance in Progress".



The electrical system must comply with applicable legislation in the country of installation.

Use components and materials with CE marking which are compliant with the Low Voltage Directive 2014/35/EU and EMC Directive 2014/30/EU.

The power supply line for the automation must be fitted with a multi-pole circuit breaker, with a suitable tripping threshold, a contact opening distance of at least 3 mm and a breaking capacity that complies with current regulations.

The power supply for the automation must be fitted with a 30 mA differential switch.

The metal parts of the structure must be earthed.

Check that the protective earthing system complies with applicable regulations in the country of installation.

The electrical cables of the automation system must be of a size and insulation class that is compliant with current legislation and laid in appropriate rigid or flexible conduits, either above or below ground.

Use separate conduits for the power supply and the 12-24 V control devices / accessories cables.

In the case of a Master-Slave configuration, a cable conduit has to be installed for the cables that connect the two electronic boards.

Check buried cable plans to ensure that there are no other electrical cables in proximity to the planned digging/drilling locations to prevent the risk of electrocution.

Check that there are no pipes in the vicinity as well.

The conduit fittings and the cable glands must prevent the entry of moisture, insects and small animals.

Protect extension connections using junction boxes with an IP 67 protection rating or higher.

The overall length of the BUS cables must not exceed 100 m.

The barrier must always be visible to prevent it from being hit accidentally; an adequate lighting system is required. It is recommended to install a flashing light in a visible position to indicate when it is moving.

For the creation of detection loops, refer to the relative instructions.

The control accessories must be positioned in areas that are always accessible and not dangerous for the user. It is recommended to position the control accessories within the field of view of the automation. This is mandatory in the case of hold-to-run controls.

If an emergency stop button has been installed, it must be EN13850 compliant.

Comply with the following heights from the ground:

- control accessories = minimum 150 cm

- emergency buttons = maximum 120 cm

If the manual controls are intended to be used by disabled or infirm persons, highlight them with suitable pictograms and make sure that these users are able to access them.

## 4.3 EXAMPLE SYSTEM



The example is purely an illustration and is only one of the possible applications of B614.

Example System	Minimum wire cross section
1 Barrier B614	
2 Mains power supply	3G 1.5 sq. mm
3 Cut out switch	
4 Key switch	
5 Flashing light	
6 Photocells BUS 2easy	2 x 0.5 sq.mm
7 Foot traffic route	

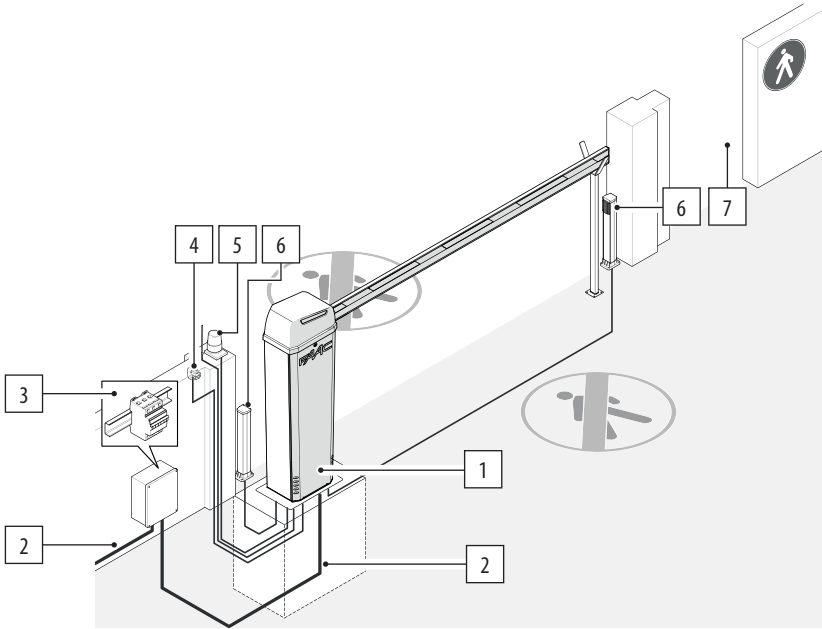

## 5. MECHANICAL INSTALLATION



Perform the operations when there is no electrical power.



The installation must comply with Standards EN 12453 and EN 12445.

Mark off the work site and prohibit access/transit. Before the barrier is fixed to the foundation there are risks of tripping and falls.

When working in the box there are risks of cutting, shearing, crushing hands due to the presence of moving parts. Until the installation is completed, the partially installed barrier must always be left blocked and with the door and upper lid always closed to prevent access to the electronic parts and the moving mechanical parts. Never install the beam before fixing the barrier body and checking it.

Until the installation is complete, never leave the barrier unguarded with the beam fitted. If the beam is fitted, the barrier must be locked with the beam open.

If installation is outside it must be done in good weather without rain or gusts of wind. If it is raining an adequate shelter for the barrier must be made until the mechanical and electronic installation is complete.

Never manage the barrier by holding the board holder.

### 5.1 TOOLS REQUIRED



8-13-17-19

Hex wrench



4-6

Allen key



Level



TOOL with TORQUE ADJUSTMENT

Where necessary for safety, a torque wrench with the specified tightening torque will be shown.

TIGHTENING TORQUE VALUE

The torque wrench and the tightening torque in Nm is shown in the figures. E.g.: HEX WRENCH 6 set at 2.5 Nm

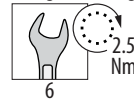

## 5.2 PLACING THE FOUNDATION PLATE

### RISKS



### PERSONAL PROTECTIVE EQUIPMENT



Perform the operations when there is no electrical power.



The barrier must be installed with the base plate  
 - The foundation schematic appended to this manual gives the characteristics of the foundation as pure approximations. The schematic considers the barrier applied to the maximum limits indicated in this manual and under the most arduous conditions. The installation engineer is responsible for the evaluation of the foundation materials and dimensions on the basis of the characteristics of the ground and place of installation. Perform structural calculations where necessary.

1. Dig into the ground. Cover with concrete, ensuring the tubing for the electrical cables come out.
2. 8 Assemble the base plate.
3. 9 Immerse the base plate in the foundation leaving the surface exposed.



The plate must be in the centre of the plinth.  
 The hole for the cables to pass through must correspond with the orientation planned for the barrier (barrier side, door side).  
 The cable tubes must emerge from the hole on the plate by around 20 cm.  
 Check the plate is horizontal using a spirit level.  
 Clean the concrete off the surface of the plate and the nuts with washers so they can be removed when necessary.

4. Wait for the concrete to set.

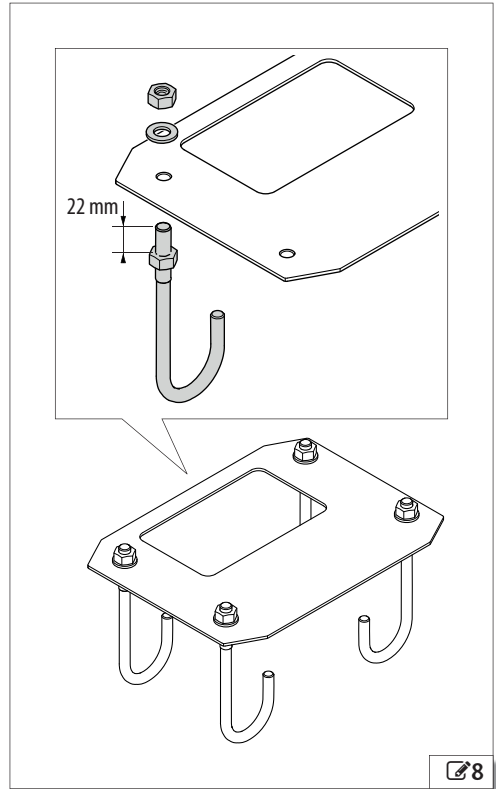

8

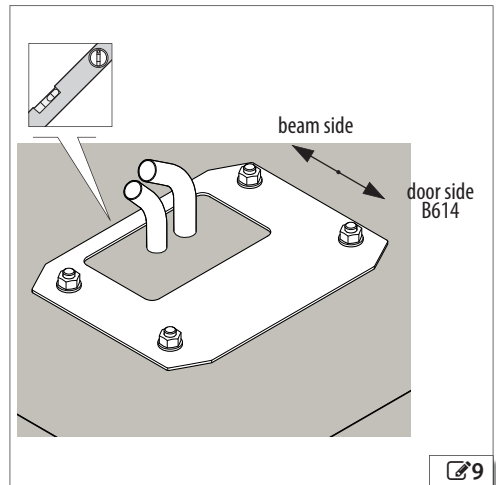

9

### 5.3 INSTALLING THE BARRIER BODY

RISKS



PERSONAL PROTECTIVE EQUIPMENT



Perform the operations when there is no electrical power.



Before you start, make sure that the plinth's concrete has solidified.

In this phase the barrier must be locked.

Never manage the barrier by holding the board holder.

1. (🔧10) Remove the 4 nuts with washers from the plate
2. (🔧11) Place the barrier body on the foundation, at the four fixing points.



Be careful not to damage the electrical cable tubes.

3. (🔧12) Fix the body of the barrier in position using a nut with washer on every fixing point of the foundation.



Use the torque wrench to tighten to the torque shown in the figure.

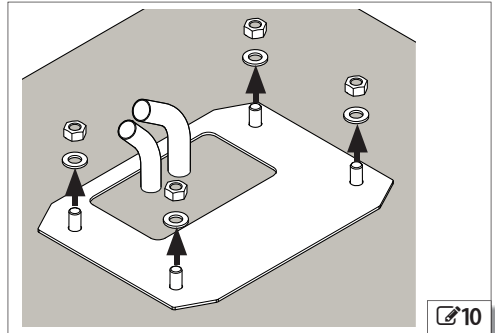

🔧10

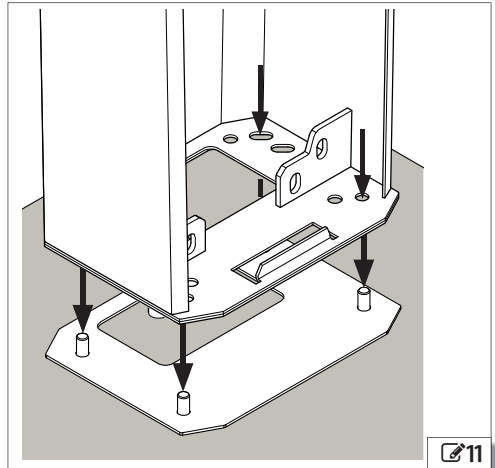

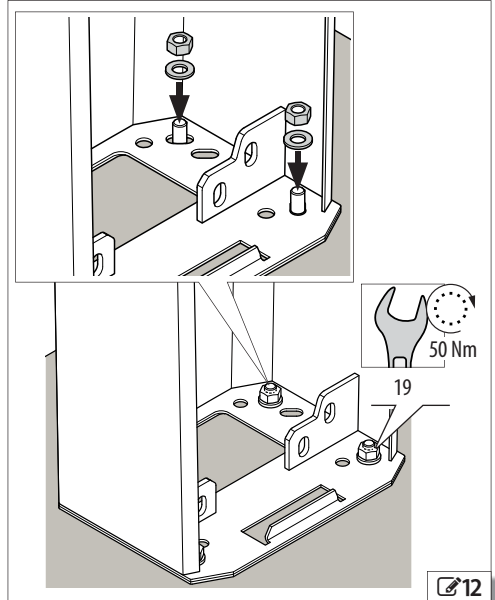

🔧11



🔧12

## FIXING THE CABLES INSIDE THE BARRIER

**i** 130 cm of cable are necessary.

1.  **13** Arrange the cables inside the barrier. Fix the cables with the cable ties provided **1**, **2** and **3**.
2.  **14** Remove bolt with washer **1**. Open cable tie **2**. Bring the cables to the board.
3. Use the screw and washer **1** to close the cable tie.

**i** The electrical connections must be made after completing the mechanical installation

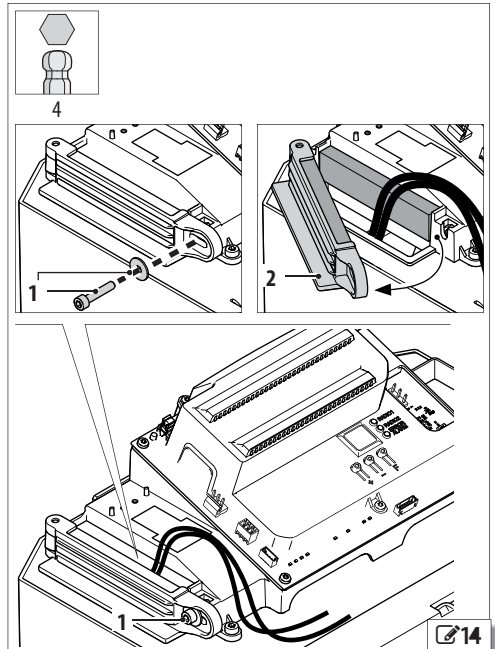
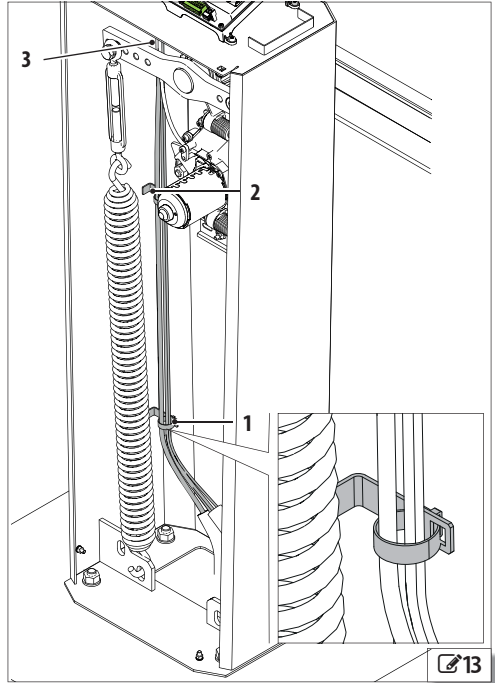

## 5.4 FITTING THE BEAM

### RISKS



### PERSONAL PROTECTIVE EQUIPMENT



- Perform the operations when there is no electrical power.
  - Before installing the beam, check the fixing of the barrier body with the tightening torques indicated.
  - Two people must move the beam.
  - If necessary, cut the beam, do not cut the end with the fixing hole in it. After the cutting remove any sharp borders and burs.
- Before fitting the beam, check the integrity of the lower rubber protection edging.

### PREPARING THE BALANCER

Before installing the beam, it is necessary to turn the balancer in the closed beam position.



- This phase requires the release of the barrier.
- Keep away from the moving elements inside the box.
  - To move the balancer, turn the drive shaft, making use if necessary of the beam fixing lever. Do not use other tools

1. Perform the release manoeuvre.
2. Turn the shaft so as to bring the balancer into contact with the closing limit switch.



#### Closing limit switch

LH barrier	1
RH barrier	2

3. Restore the automatic operation.

### RECTANGULAR BEAM

1.  Screw up the guide 1 in the drive shaft.
2. Insert lever 2 in the drive shaft horizontally in contact with seeger ring 3.





The spacer must not be used and must be eliminated.

3.  Remove guide 1 and replace it.
4. Fix in position with screw 2, interposing washer 3.

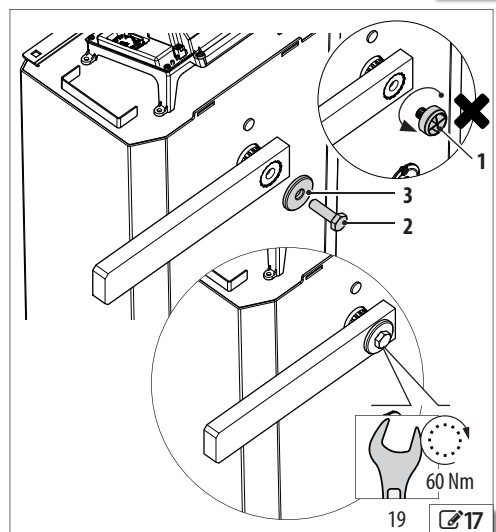
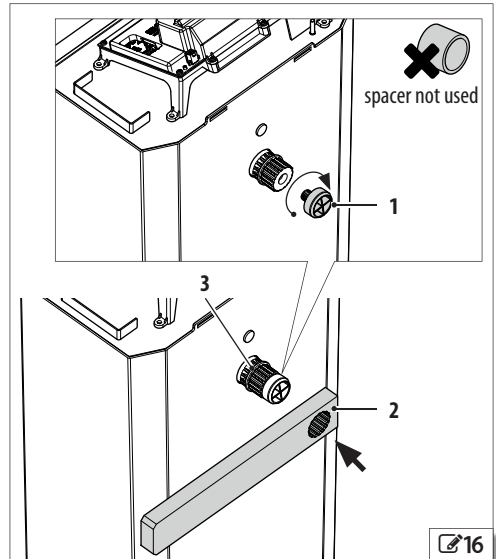
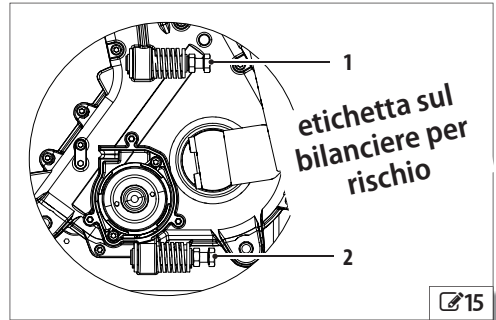

Use the torque wrench to tighten to the torque shown in the figure.



5.  18 Insert beam 1 in the lever.



To make the insertion of the beam easier, use a stand for resting it at the end.

6. Line up the two holes underneath (slide the lower edging temporarily to uncover the holes).
7. Fix the beam with screws 2, interposing the washers (reposition the lower edging).
8.  19 Insert cover 1 and fix it with screw 2, interposing the washer.
9. Insert the cover 3 at the end of the beam.



 20 Leave the beam supported to take the weight until the assembly of the spring is complete.

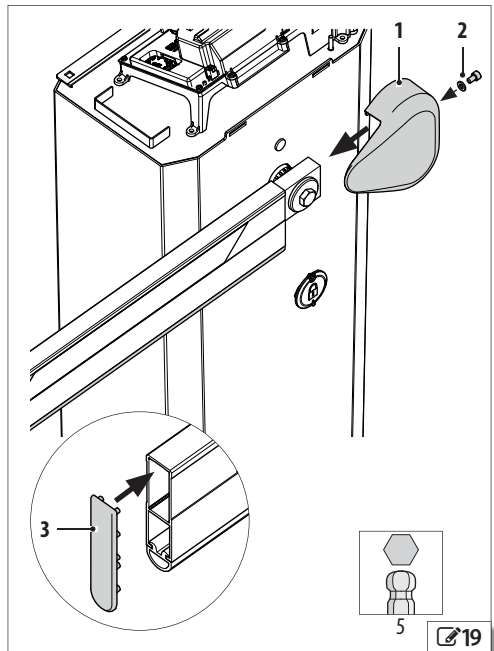
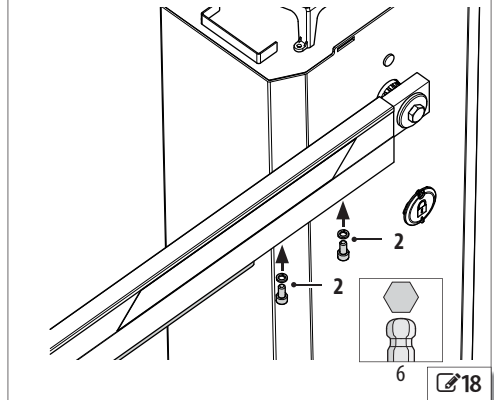
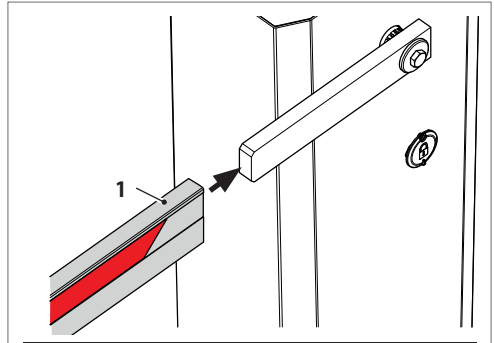
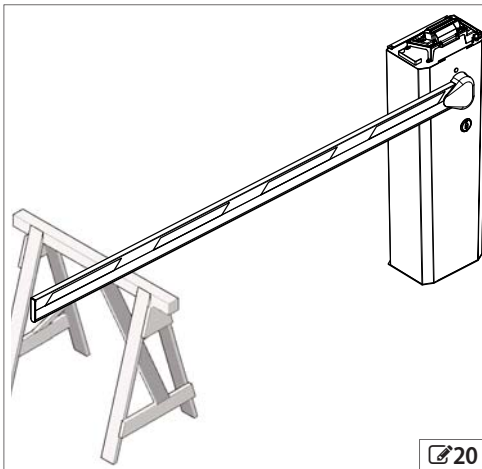



**ROUND BEAM**

1. (🔧21) Screw up the guide 1 in the drive shaft.
2. Insert plate 2 in the drive shaft horizontally in contact with seeger ring 3.

⚠️ Position the plate with the holes 4 at the bottom.

📌 The spacer 5 must not be used and must be eliminated.

3. (🔧22) Removing guide 1 and replacing it.
4. Insert the adaptor 2, horizontally.
5. Fix in position with screw 3, interposing washers 4 and 5.

⚠️ Use the torque wrench to tighten to the torque shown in the figure.



6. (🔧23) Insert the beam 1 in a horizontal position.

⚠️ To make the insertion of the beam easier, use a stand for resting it at the end.

7. Insert counter plate 2.
8. Fix in position with screws 3, interposing the washers.

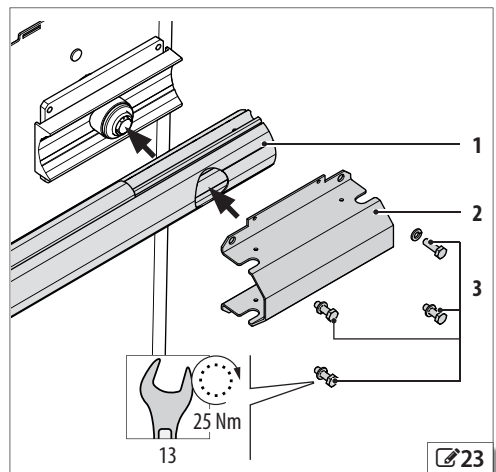
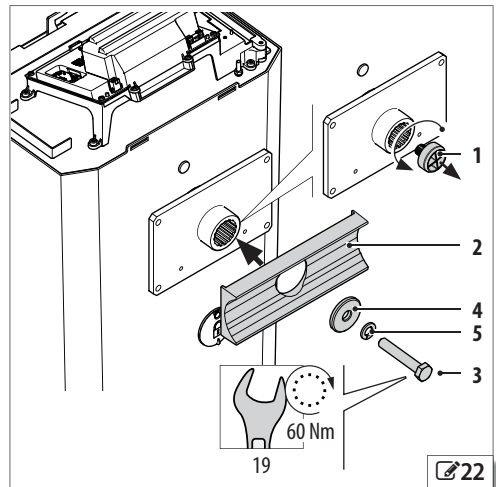
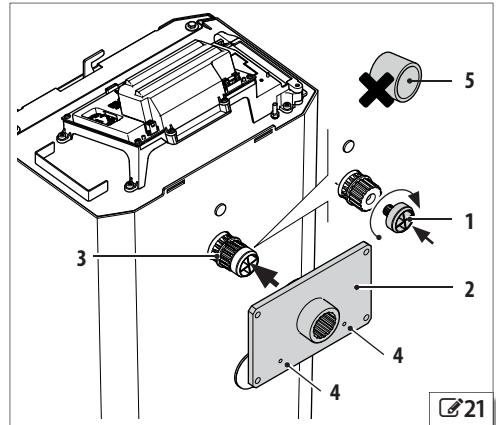
⚠️ Use the torque wrench to tighten to the torque shown in the figure.



9.  24) Insert cover 1 and fix it with the screws 2.
10.  25) Apply the reflective papers 1 on both sides of the beam.
11. Insert cover 2 at the end of beam and fix with screws 3.



Leave the beam supported to take the weight until the assembly of the spring is complete.

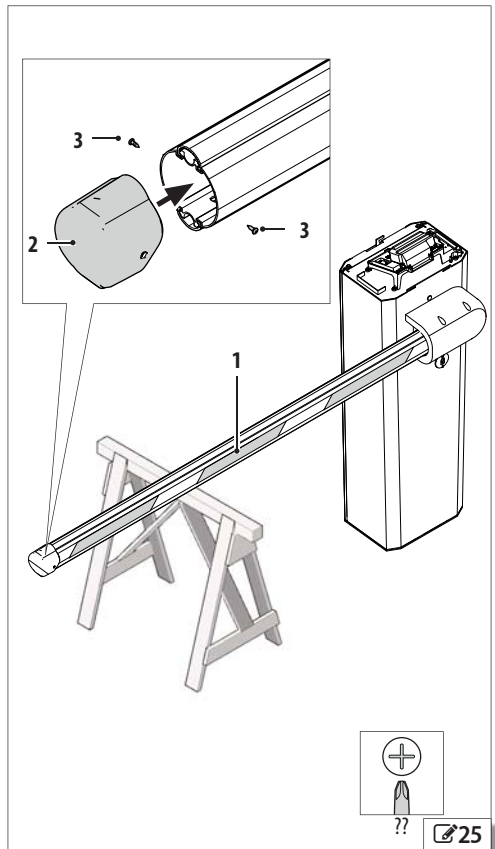
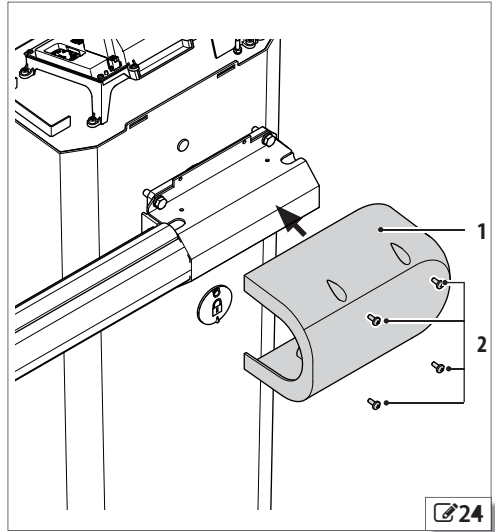

## 5.5 FITTING THE SPRING

### RISKS



### PERSONAL PROTECTIVE EQUIPMENT



The balancing of the barrier requires:

- fitting of the tie rod in the appropriate position
- fitting of the appropriate spring: single or double
- manual adjustment of the tie rod

- Perform the operations when there is no electrical power.

- The spring appropriate for the configuration and length of the beam is defined in the balance chart (see 2). Respect the holes for hooking to the balancer and the base indicated.

- The accessories on the beam must be considered when choosing the balancing spring (single or double). Following the addition or elimination of the accessories at a later time, it might be necessary to change the spring.

### TIE ROD

This phase requires the release of the barrier.

- Keep away from the moving elements inside the box.
- Do not leave the beam vertical when the barrier is unlocked.
- Respect the fixing hole indicated in the balancing charts (see 2).

1. Perform the release manoeuvre.
2. Lifting the beam completely vertically.
3. Restore the automatic operation
4. Align bushing 1 and tie rod 2 on the appropriate hole. Fix in position with screw 3, interposing washer 3.

Use the torque wrench to tighten to the torque shown in the figure.

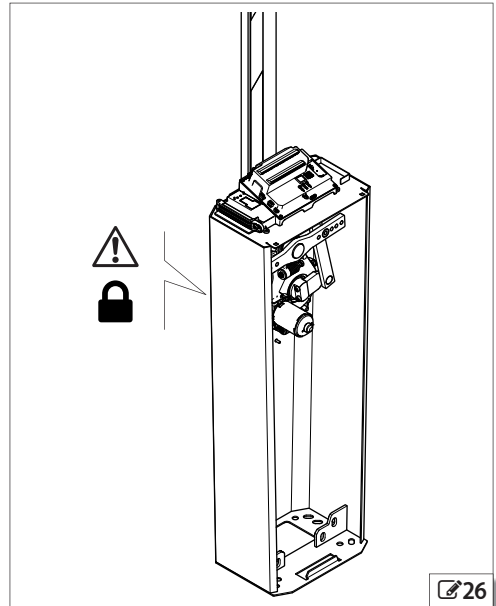

26

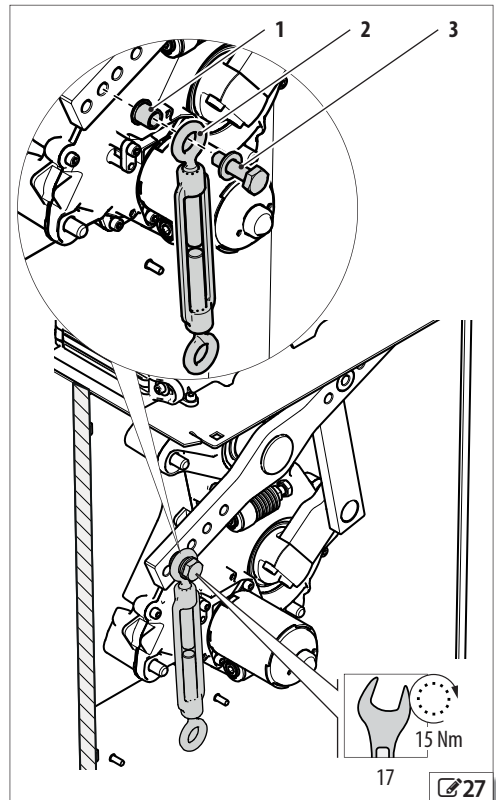

17

27

## SINGLE SPRING

1. (🔧28) Hook the spring to the tie rod and the appropriate hole, at the bottom of the barrier body.

⚠️ Respect the hole indicated in the balancing charts (see 2).

📌 Lengthen the tie rod by manually unscrewing it to facilitate the operation

2. Shorten the tie rod by screwing it up manually to place the spring under tension.

⚠️ Keep away from the spring coils.

3. Restore the automatic operation

## DOUBLE SPRING

1. (🔧29) Creating the double spring by joining the two springs at the ends with the plates 1 and 2.

⚠️ Respect the hole indicated in the balancing charts (see 2).

📌 Lengthen the tie rod by manually unscrewing it to facilitate the operation

3. Shorten the tie rod by screwing it up manually to place the spring under tension.

⚠️ Keep away from the spring coils.

4. Restore the automatic operation.

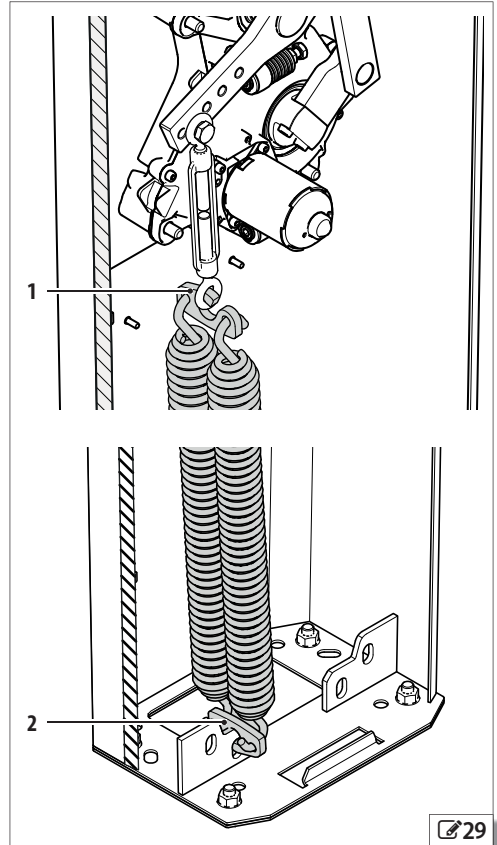
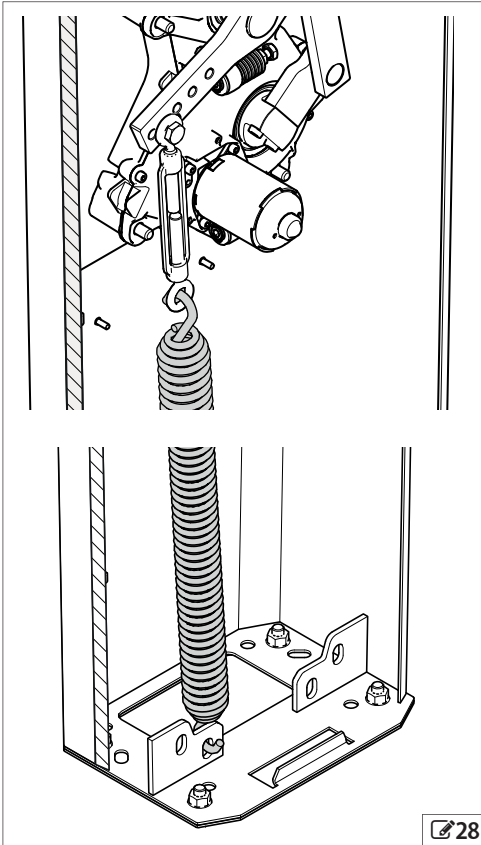

## 5.6 ACCESSORIES ON THE BEAM

**!** The accessories on the beam must be considered when choosing the balancer spring (single or double).

The accessories on the beam must be fitted before balancing the beam. If the accessories are added or removed later it may be necessary to change the spring. After a modification of the beam, it is necessary to balance it again.

The spring appropriate for the configuration and length of the beam is defined in the balancing charts (see  2).

**i** See § 10 for fitting accessories to the beam.

## 5.7 BALANCING THE BEAM

### RISKS



### PERSONAL PROTECTIVE EQUIPMENT



**!** This phase requires the release of the barrier.

- Perform the release manoeuvre when there is no electrical power.
- Keep away from the moving elements inside the box and from the coil spires.
- Do not leave the beam vertical when the barrier is unlocked.

**i** See the specific instructions for balancing a jointed beam.

1. Perform the release manoeuvre and position the beam horizontally.

**!** Support the beam during the movement.

2. Leave the beam free: it is balanced when it rises to 45°.

3. Make the adjustment, if necessary:

- to raise the beam further, it is necessary to shorten the tie rod
- to lower the beam further, it is necessary to lengthen the tie rod

4. Repeat the regulation until obtaining the balancing: the beam holds the position at 45°.

5. Restore the automatic operation.

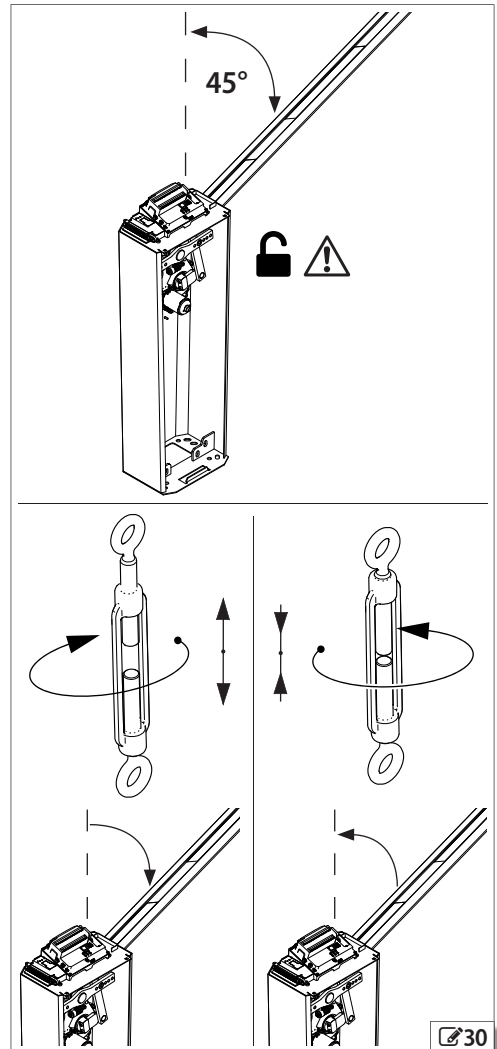

## 5.8 LIMIT SWITCH ADJUSTMENT

### RISKS



### PERSONAL PROTECTIVE EQUIPMENT



The actuator is supplied with regulated limit switches. It is possible to work on the limit switches to adjust the beam's horizontal status and verticality.

31	Limit switch A	Limit switch B
RH barrier	vertical beam	horizontal beam
LH barrier	horizontal beam	vertical beam



This phase requires the release of the barrier.

- Perform the release manoeuvre when there is no electrical power.
- Keep away from the moving elements inside the box and from the coil spires.
- Do not leave the beam vertical when the barrier is unlocked.

1. At the same time, loosen lock nut **1** and the screw **2**.
2. Keep the lock nut still and manually regulate the stop with screw **3**.
3. Block the lock nut **1** with the hex wrench and tighten the screw with Allen key **2**.
4. Check the correct adjustment of the limit switch. Repeat the sequence if necessary. At the end, tighten screw **2** definitively with the indicated torque.



Use the torque wrench to tighten to the torque shown in the figure.

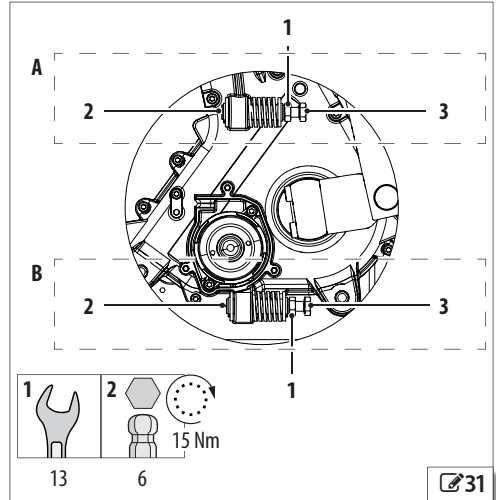

31

### 5.9 EARTHING THE DOOR

1. (🔧32) Use the cable supplied and fix it using the toothed washer and nut on the base and on the door. Respect the insertion order indicated in the figure.

### 5.10 CLOSING THE DOOR



The door must be closed before any manoeuvres are performed, even manually.  
Handle the door carefully so as not to damage the earth cable.

1. (🔧33) Insert the lower slot of the door in its place 1, at the bottom of the box.
2. Close the door and fix it in place with screws 2 (provided).

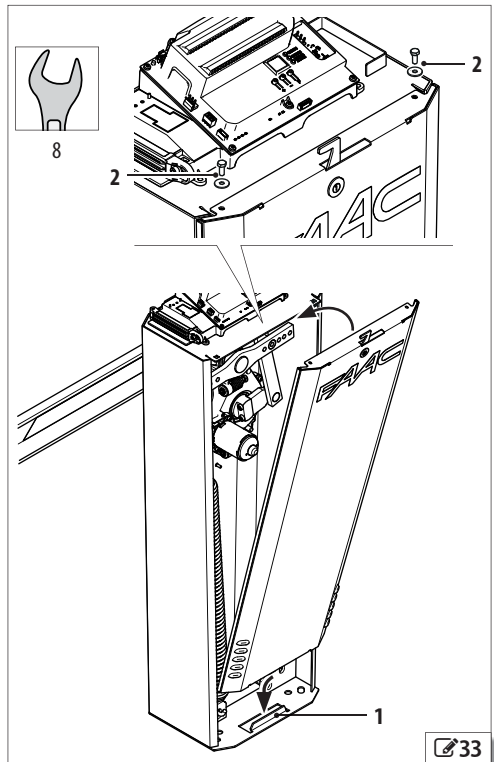
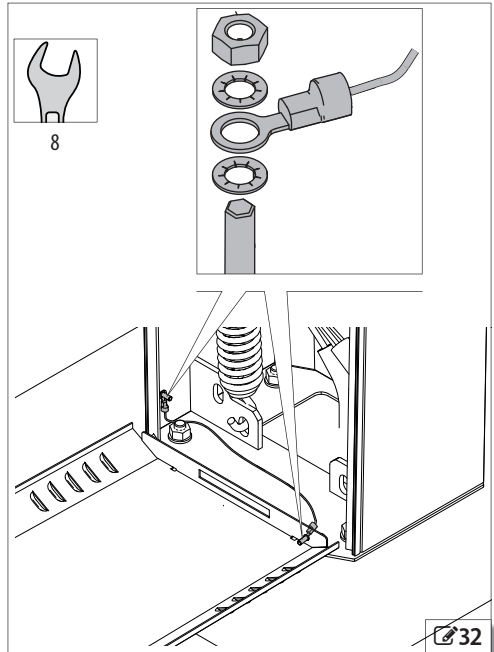

## 5.11 CLOSING THE UPPER LID

**i** If there is a head lighting kit, insert the connector before closing the cover (see § 10).

1. **34** With the cover inclined, insert markers **1** in slots **2** on the box (rod side), then lower it on the opposite side.
2. Close with the key: turn in an anticlockwise direction.
3. Check the closure of the cover: try to lift it from the two beam ends at the same time and then on the opposite side.

**i** For the seal of the closure it is necessary for the door of the barrier to be closed and fixed definitively.

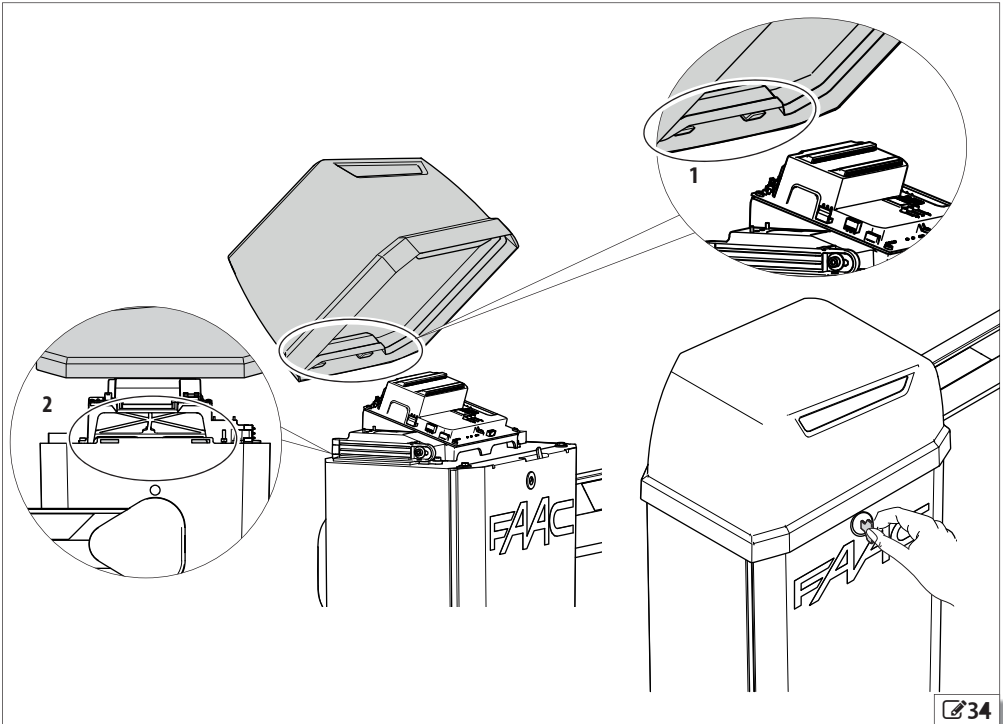



## 6. INSTALLING OPTIONAL FEATURES



The installation must comply with Standards EN 12453 and EN 12445.

When working in the box there are risks of cutting, shearing, crushing hands due to the presence of moving parts. Until the installation is completed, the partially installed barrier must always be left blocked and with the door and upper lid always closed to prevent access to the electronic parts and the moving mechanical parts. Never install the beam before fixing the barrier body and checking it.

Until the installation is complete, never leave the barrier unguarded with the beam fitted.

Mark off the work site and prohibit access/transit.

If installation is outside, it must be done in good weather without rain or gusts of wind. If it is raining, an adequate shelter for the barrier must be made until the mechanical and electronic installation is complete.

Never manage the barrier by holding the board holder.

### 6.1 PERSONALISED KEY RELEASE

Work in progress

## 7. ELECTRONIC INSTALLATION

### RISKS



### PERSONAL PROTECTIVE EQUIPMENT



**ALWAYS DISCONNECT THE POWER SUPPLY** before working on the board. Turn power on only after having made all the electrical connections and carried out the preliminary start-up checks.

The board cover must never be removed unless the board is to be replaced. No installation operation requires the removal of the cover.

### 7.1 BOARD E614

7 Board technical data sheet E614

	230V~	115V~
Supply voltage	220-240 V~ 50/60 Hz	115V~ +/-10% 50/60 Hz
Max power	150 W	150 W
Accessory output voltage	24 V===	24 V===
Max. accessories load	500 mA	500 mA
Max. accessories load BUS 2easy	500 mA	500 mA
Max. flashing light load		
Ambient operating temperature	-20 °C - +55 °C	

### COMPONENTS

See figure 42

BOARD:	
J1	Mains power supply terminal board
J3	Terminal board for BUS 2easy
J6	Accessory/input terminal board
J7	Radio module connector XF
J8	Battery connector XBAT 24
J10	Terminal board for external detector LOOP1
J11	Connector for encoder
J13	Terminal board for external detector LOOP2
J16	Terminal board for external flashing light
J18	Terminal board for the beam lights
J20	Terminal board for outputs
J21	Connector for integrated flasher
J23	Connector for motor
F3	Board protection fuse (F3 = T2.5A)
DISPLAY	Programming display

BOARD:	
DL1	Device signalling LED to BUS 2easy ACTIVE
DL2	BUS 2easy "BUS MON" diagnostic signalling LED
DL3	"RADIO1" (OMNIDEC) signalling LED
DL4	"RADIO2" (OMNIDEC) signalling LED
DL5	Error/alarm signalling LED
DL8	EMER status LED
DL9	STOP/FSW-CL status LED
DL10	CLOSE status LED
DL11	OPEN status LED
DL12	LOOP1 status LED
DL13	LOOP2 status LED

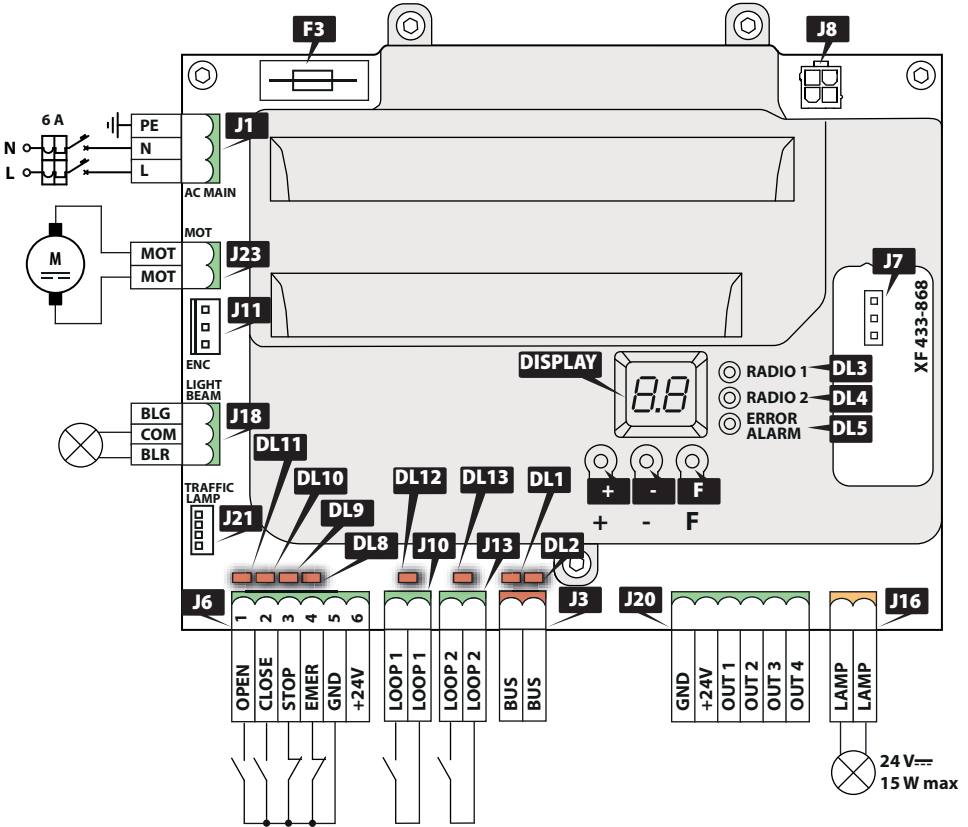

ENGLISH

Translation of the original instructions

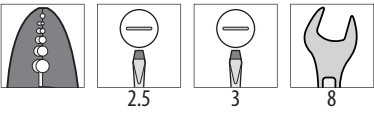

## 7.2 CONNECTIONS



Before making electrical connections, cut off the automation power supply. If the disconnect switch is not in view, apply a warning sign stating "WARNING - Maintenance in Progress".



In Master-Slave configuration, see § 11.

### CONTROL DEVICES

( 36) Connect the devices to the terminal board J6 of the board.



Multiple NO contacts on same input must be connected in parallel. Multiple NC contacts on same input must be connected in series.

### TERMINAL BOARD J6:

1	OPEN	NO contact, connect a button or other pulse giver that commands the opening of the barrier, by closing a contact
2	CLOSE	NO contact, connect a button or other pulse giver that commands the closure of the barrier, by closing a contact
	STOP	Configured as STOP (default): NC contact, connect a button or other pulse giver that commands the stopping of the barrier, by opening a contact
		If NO device is connected, make a jump with GND
3	FSW-CL	Configured as FSW-CL (see SP function in Advanced programming): NC contact, connect a photoelectric cell or other device that commands the inversion on opening, by opening a contact during the closure
		If NO device is connected, make a jump with GND
4	EMER	NC contact, connect a button or other pulse giver that commands the emergency opening of the barrier, by opening a contact
		If NO device is connected, make a jump with GND
7	GND	Accessories power supply negative and common contact (1 A max.)
8-9	+	Accessories power supply positive 24 V == (1 A max.).

### STOP input configured as FSW-CL

For the connection of photocells with relay contact, it is necessary to configure the STOP input as FSW-CL. Connect the negative of the transmitter (TX) power supply of the photocells to an OUT output configured as Fail-Safe. In this way the functioning of the pho-

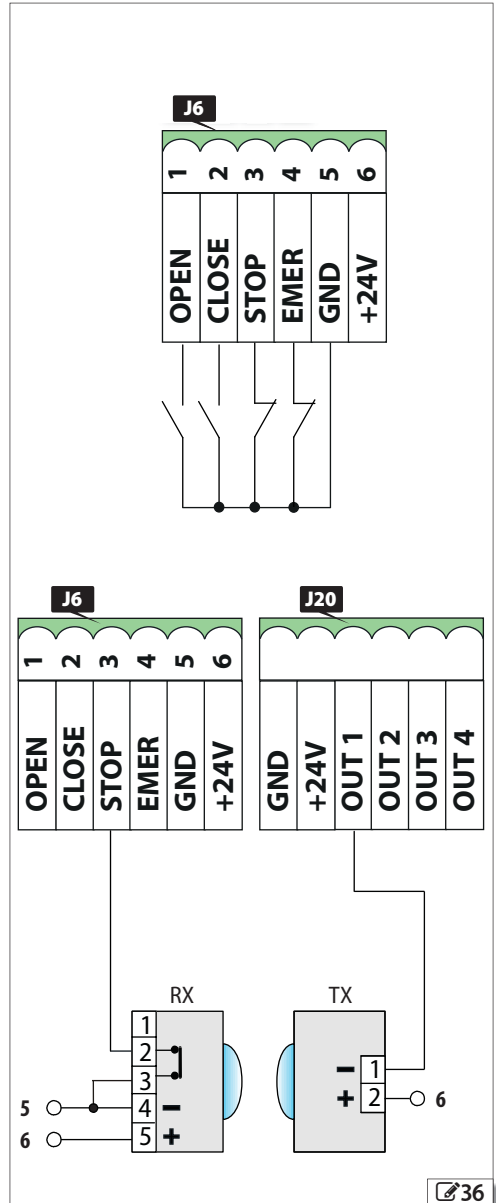

36

tocells is checked before each closure: the test consists in breaking the power supply to the TX momentarily and checking the change of status of the input. If the test fails the electronic board does not command the movement.

**EXTERNAL LOOPS**

**!** The magnetic coil detectors must not be used to detect pedestrians, cycles and motorbikes. If it is not possible to prevent them passing, other devices such as photocells are necessary.

**37** Connect the magnetic coil detectors to terminal boards J10 (LOOP 1) or J13 (LOOP 2).

LOOP 1	Opening coil NO contact, connect a detector that commands the opening of the barrier when a contact is closed
LOOP 2	Transit coil NO contact, connect a detector that commands the closure at the disengagement when a contact is closed The engagement of the loop during the closure inverts the movement; the barrier cannot close as long as the loop is engaged

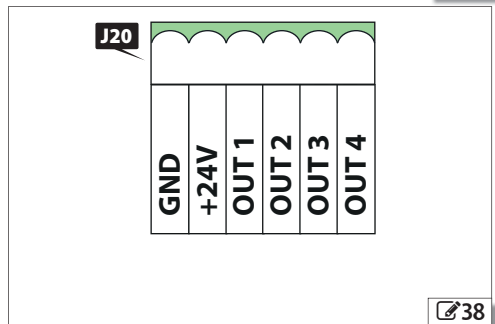
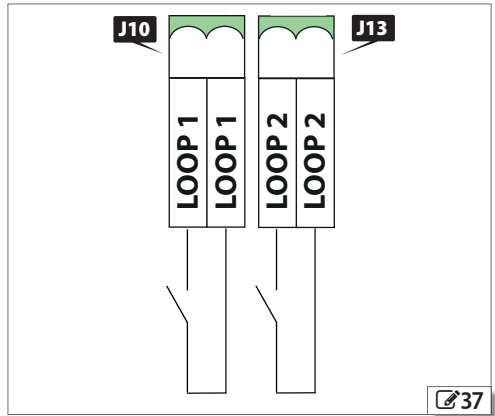

**BUS DEVICES**

**i** If no BUS 2easy devices are used, leave the BUS 2easy terminal board free.

See § 10.4 for the connection and orientation.

**OUT OUTPUTS**

**i** Respect the 100mA max load for each output.

Open Collector Outputs: the activation of the output and its polarity can be configured by Advanced programming.

	OUT active	OUT not active
NO polarity	0V	open circuit
NC polarity	open circuit	0V

**38** Connect the devices required to terminal board J20.

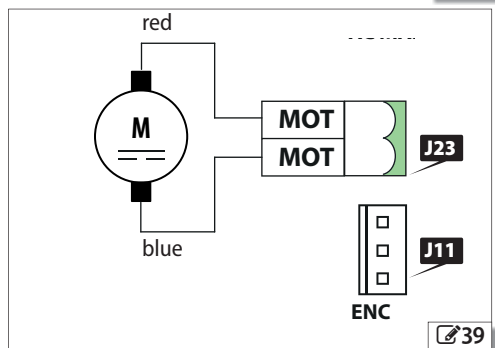

**24 V FLASHING LIGHT**

See § 10.1 for the connection.

**MOTOR**

**39** The motor wire is connected in the factory for a RH barrier. Invert the wires if a LH barrier is being installed.

**ENCODER**

The encoder wire is connected in the factory.

**i** The encoder must always be connected in order for the automation system to operate.

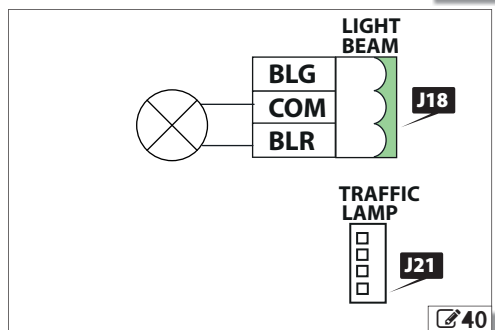

ENGLISH  
Translation of the original instructions

## BEAM LIGHTS

See § 10.5 and § 10.6 for the connection.

## INTEGRATED FLASHING LIGHT

See § 10.6 for the connection.

## BATTERY XBAT 24

See § 10.2 for the connection.

## RADIO MODULE XF

See § 10.3 for the installation.

## MAINS SUPPLY AND EARTHING



Use a 3G 1.5 mm<sup>2</sup> wire (not supplied).



The grounding between board and box is done in the factory. Do not remove the connection.

1. Crimp the earth wire of the power cable to the cable terminal provided.
2.  Insert 2 washers, the cable terminal and the nut provided on the earth plug respecting the insertion order.
3. Tighten the nut.
4. Connect the phase wires and neutral to J1.

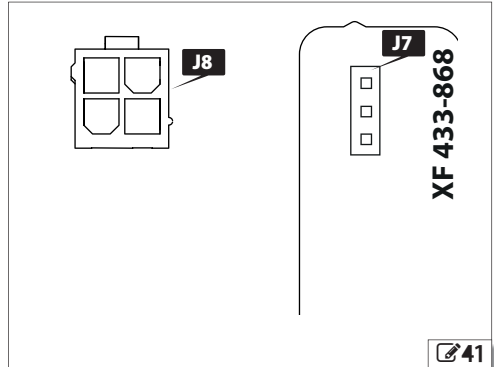

 41

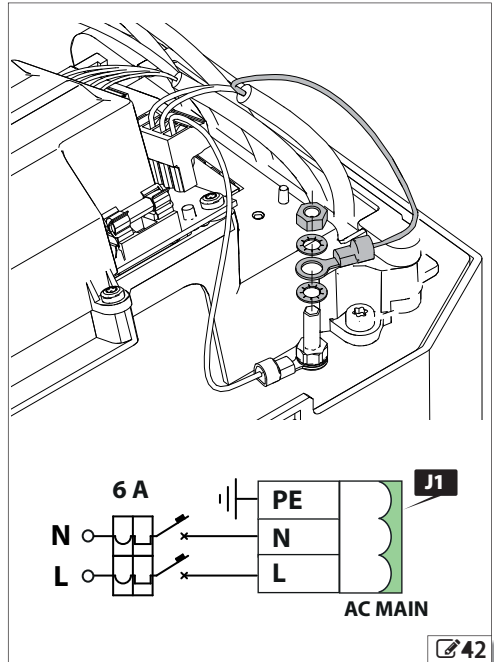

 42

## 8. START-UP

### RISKS



### PERSONAL PROTECTIVE EQUIPMENT



During operation there is a risk of cutting, crushing or the total loss of hands due to the moving parts inside the box. If two barriers are installed in the following configuration Master-Slave, before beginning the start up of the Master, it is necessary to have configured the Slave barrier (see § 11).

1. Check that the B614 is locked.
2. Power up the plant (Master barrier) . The board lights up and the display then comes on:
  - firmware version (2 digits separated by a dot)
  - flashing if a set-up or the automation status is requested
3. Check the status of the LEDs at rest (see § 12.1).



The BUS 2easy LEDs must be checked after the devices have been registered.

4. Memorise the remote controls present on the plant (see § 10.3).
5. Program E614 without performing the set-up.



For the barrier to work properly, set the parameter  $cF$  dependent on the beam length.

6. Register the BUS 2easy devices, if they are installed (see § 10.4).
7. Check the barrier's direction of travel (see § 12.2).
8. Perform the set-up (see § 8.3).
9. If the XBAT 24 battery is being used:
  - Cut off the plant's power supply
  - Connect the battery XBAT 24
  - Switch on power to the system.

## 8.1 PROGRAMMING

### BASIC PROGRAMMING

1. Press and hold down **F** until the first basic function appears. (Each function is displayed as long as **F** remains pressed).



2. Release: the value of the function appears (default or programmed).

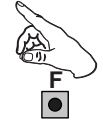

3. Use the **+** or **-** button to modify the value.

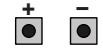

4. Press **F** to confirm the value displayed. Go to the next function. The modified value becomes effective immediately.

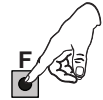

Proceed in the same way for all the functions. The last function (**SE**) allows you to close the program.

5. In **SE** select **Y** or **NO** using the **+/-** buttons:  
**Y** = save the new program  
**NO** = DO NOT save the new program

6. Press **F** to confirm and close the program. It returns to the automation system status view.

To **exit from the programming mode at any time:**

press and hold down **F** and then also **-** to move directly to **SE**.

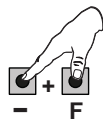

## ADVANCED PROGRAMMING

1. Press and hold down **F** and then **+** as well, until the first advanced function appears. (Each function is displayed as long as **F** remains pressed).

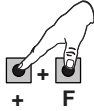

2. Release: the value of the function appears (default or programmed).

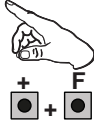

3. Use the **+** or **-** button to modify the value.



4. Press **F** to confirm the value displayed. Go to the next function. The modified value becomes effective immediately.

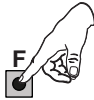

Proceed in the same way for all the functions. (S<sub>t</sub>) allows you to close the program.

The last function

5. In S<sub>t</sub> select **Y** or **nO** using the **+/-** buttons:  
**Y** = save the new program  
**nO** = DO NOT save the new program

6. Press **F** to confirm and close the program. It returns to the automation system status view.

To **exit from the programming mode at any time:**

press and hold down **F** and then **-** as well to move directly to S<sub>t</sub>.

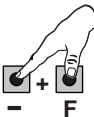

## 8 Basic programming

Basic function	Default
<b>F</b> <b>BARRIER CONFIGURATION</b> Set functional parameters (including opening and closing speed) dependent on the beam length. <ul style="list-style-type: none"> <li><b>01</b> beam up to 3m</li> <li><b>02</b> beam from 3m to 4m</li> <li><b>03</b> beam from 4m to 5m</li> </ul>	03
<b>F</b> <b>DEFAULT</b> Displayed if the board is configured with the factory settings (default). <ul style="list-style-type: none"> <li><b>Y</b> indicates that all set values correspond to the defaults</li> <li><b>nO</b> indicates that one or more set values are different from the defaults</li> </ul> Select <b>Y</b> if you wish to restore the default configuration.	Y
<b>S<sub>t</sub></b> <b>MASTER/SLAVE configuration.</b> <ul style="list-style-type: none"> <li><b>MA</b> Configures the board in Mastermode</li> <li><b>SL</b> Configures the board in Slavemode</li> </ul>	MA
<p><b>i</b> The following parameters are not displayed on the Slave board: L<sub>0</sub>-P<sub>A</sub>-b<sub>u</sub>-t<sub>L</sub>-P<sub>F</sub>-t<sub>B</sub>-F. See the relative section.</p>	
<b>L<sub>0</sub></b> <b>FUNCTIONING LOGIC</b> <ul style="list-style-type: none"> <li><b>EP</b> Semi-automatic step by step</li> <li><b>A</b> Automatic</li> <li><b>AP</b> Automatic step by step</li> <li><b>b</b> Semiautomatic B</li> <li><b>bC</b> - Semiautomatic B on opening/person present</li> <li><b>C</b> on closure</li> <li><b>C</b> Person present</li> <li><b>P</b> Car park</li> </ul>	EP
<p><b>i</b> See the dedicated section for the functioning of the logics</p>	
<b>PA</b> <b>PAUSE TIME</b> Adjustable from 00 a 59 s, to 1 sec steps. If 59 is exceeded, the display changes to indicate minutes and tens of seconds (separated by a dot) and can be adjusted in steps of 10 seconds, up to a maximum of 9.5 minutes.	20
<p><b>i</b> E.g.: if the display indicates 2.5, the time is 2 min and 50 sec.</p>	
<b>S<sub>o</sub></b> <b>OPENING SPEED</b> <ul style="list-style-type: none"> <li><b>01</b> minimum speed</li> <li><b>10</b> maximum speed</li> </ul>	See tab. Speed default



Basic function	Default
<b>S<sub>c</sub> CLOSURE SPEED</b>	See tab. Speed de- fault
01 minimum speed	
10 maximum speed	
<b>bu DEVICE REGISTRATION BUS 2easy</b>	no
<b>i</b> See the relative section.	
<b>M Dead-man MOTOR OPERATION mode</b>	--
+ OPENS (displaying cF) as long as the button remains pressed.	
- CLOSES (displaying cL) as long as the button remains pressed.	
<b>EtL SET-UP</b>	no
Acquire the limit switch positions.	
<b>i</b> See the relative section.	
<b>St LEAVING THE PROGRAMMING MODE</b>	Y
Y save and exit from programming mode	
no exit from programming mode without saving	
Press <b>F</b> to confirm. After exiting, the display indicates the status of the automation system:	
00 = Closed	
01 = Open	
02 = Stationary then opens	
03 = Stationary then closes	
04 = Pausing	
05 = Opening	
06 = Closing	
07 = Failsafe underway	
08 = Check of BUS 2easy device underway	
09 = Pre-flashing and then opens	
10 = Pre-flashing and then closes	
11 = Opening in emergency	

**9 Speed default**

	cF 01	cF 02	cF 03
S <sub>o</sub>	10	06	02
S <sub>c</sub>	08	04	02

**10 Advanced programming**

Advanced function	Default
<b>PF PRE-FLASHING</b>	no
no disabled	
0c preflashing 3 sec. before each movement	
<b>FD DRIVING FORCE ON OPENING</b>	50
01 minimum power	
50 maximum power	
<b>FC DRIVING FORCE ON CLOSURE</b>	50
01 minimum power	
50 maximum power	
<b>SP STOP INPUT CONFIGURATION</b>	00
It defines the function of the STOP input	
00 (STOP) Stop	
02 (FSW-CL) Closure photoelectric cell	
<b>t OPERATING TIME (time-out)</b>	5.0
Set a higher value than the time the barrier needs to open/close completely.	
This can be regulated from 0 to 59 secs. in 1 sec steps. Afterwards, the display changes in minutes and tens of seconds (separated by a dot) and the time is regulated in 10 sec. steps, up to a maximum value of 9.5 minutes.	
E.g.: if the display indicates 2.5, the pause time is 2 min and 50 sec.	
<b>i</b> In the case of a plant with a Master/ Slave configuration an operating time must be set on the Master central control unit that takes account of the movement of both the barriers.	
<b>oI OUT OUTPUT 1 CONFIGURATION</b>	00
00 Always active	
01 failsafe	
02 telltale light (on during opening/pause/open, flashing on closure, off when closed)	
03 courtesy light	
05 barrier open or in pause mode	
06 barrier closed	
07 barrier moving	
08 barrier in emergency mode	
09 barrier opening	
10 barrier closing	
12 safety device active	
13 light column (active in pause mode/open, turns off on closure)	
15 step by step activation through second radio channel	
19 battery operation	
20 Loop1 engaged	
21 Loop2 engaged	

Advanced function	Default
<b>P1 OUT OUTPUT 1 POLARITY</b> 4 NC output no NO output If output ol = 01 (Fail-safe) configure P1 = no.	no
o2 see ol	
P2 see P1	
o3 see ol	
P3 see P1	
o4 see ol	
P4 see P1	
<b>t0 OUT OUTPUT 1 TIMING</b> (only displayed if one of the outputs is configured as courtesy light) This defines the timing of the output from 1 to 59 minutes in 1 minute steps.	02
<b>bF BATTERY OPERATION</b> 01 continues to function until completely dead 02 the barrier opens when the mains power is interrupted 03 the barrier closes when the mains power is interrupted	01
<b>o5 INTEGRATED flashing light OPERATING MODE</b> 01 light column (steady green with barrier in pause mode/open, red flashing during movement, red steady with barrier closed) 02 flashing light (flashing red during movement, off in all other states)	01
<b>bL BEAM LIGHT OPERATIONAL MODE</b> 01 lights on with barrier closed, off with barrier in pause mode/open, flashing during the movement 02 lights off with barrier in pause mode/open, flashing in all other states	01
<b>AS MAINTENANCE REQUEST - CYCLE COUNTER (linked to the next two functions)</b> If activated, at the end of the countdown (settable with the two subsequent "Cycle Programming" functions) it activates the LAMP output for a period of 4 sec every 30 sec (intervention required). This can be useful to set scheduled maintenance interventions. 4 Active no Excluded	no

Advanced function	Default
<b>nc CYCLE PROGRAMMING IN THOUSANDS</b> This makes it possible to set a countdown of the plant operating cycles from 0 to 99 (thousands of cycles). The value displayed is updated as the cycles progress, integrating with the nC value (99 decreasing by nC corresponding to 1 nC decrease). The function can be used, in combination with nC, to verify the use of the plant and for the "Request for assistance"	00
<b>nC CYCLE PROGRAMMING IN HUNDREDS OF THOUSANDS</b> This makes it possible to set a countdown of the plant operating cycles from 0 to 99 (hundreds of thousands of cycles). The value displayed is updated as the cycles progress, integrating with the nC value. (1 nC decrease corresponds to 99 nC decreases). The function can be used in combination with nC, to verify plant use and for the "Request for Assistance".	00
<b>St AUTOMATION SYSTEM STATUS:</b> See St in the Basic programming	4

## 8.2 OPERATING LOGICS



In all the logics:

- the STOP command has the priority and stops the automation system from working
- the STOP command has the priority and opens the automation system.

### EP - SEMI-AUTOMATIC STEP BY STEP

The EP logic requires the use of just the OPEN command:

- OPEN when the barrier is closed it commands the opening.
- OPEN when the barrier is open it commands the closure.
- OPEN during the movement it stops
- OPEN after the stop, it reverses in movement.



The CLOSE command always commands the closure.

### FP - AUTOMATIC

Logic FP only requires the OPEN command:

- OPEN when the barrier is closed, it commands the opening. After the pause time, the barrier closes again automatically.
- OPEN when the barrier is open in pause mode, it reloads the pause time. (Even the intervention of the photocells reloads the pause time)
- OPEN during opening is ignored.
- OPEN during the closure it causes reopening.



The CLOSE command always commands the closure.

### FP - AUTOMATIC STEP-BY-STEP

The FP logic requires the use of just the OPEN command:

- OPEN when the barrier is closed, it commands the opening. After the pause time, the barrier closes again automatically.
- OPEN when the barrier is open in pause mode it locks. (Even the intervention of the photocells during the pause mode reloads the pause time)
- OPEN during the opening locks.
- OPEN during the closure causes reopening.



The CLOSE command always commands the closure.

### b - SEMI-AUTOMATIC B

Logic b requires the use of the OPEN and CLOSE commands:

- OPEN when the barrier is closed, it commands the opening.
- CLOSE when the barrier is open, it commands the closure.
- CLOSE during opening it causes reclosure.

- OPEN during closure it causes reopening.

### b - SEMIAUTOMATIC B ON OPENING/ PERSON PRESENT C ON CLOSURE

b logic requires the use of the OPEN jog command on opening and CLOSE maintained on closure. The activation of the CLOSE command on closure must be wanted and the barrier must be visible.

- OPEN when the barrier is closed it commands the opening.
- CLOSE maintained closes the barrier.

### C - DEAD-MAN

Logic C requires the use of maintained OPEN and CLOSE commands. The control must be activated intentionally and the barrier must be visible.

- Maintained OPEN commands the opening.
- Maintained CLOSE commands the closure.
- If the photocells are triggered, movement is stopped.

### P - CARPARK

Logic P requires the use of the OPEN and CLOSE commands:

- OPEN when the barrier is closed causes it to open.
- CLOSE when the barrier is open causes it to close.
- CLOSE during opening it causes reclosure after opening.
- OPEN during opening causes it to open again.
- The triggering of the photocells during closure stops the movement, on disengagement the barrier continues to close.

## 8.3 SET-UP

The set-up procedure enables the limit switch positions to be memorised.

### The system needs to be set-up:

- When the automation system is first started
- When the board has been replaced
- Each time the display shows  $\square$  flashing and the automation system does not work
- Following any variation in the position of the limit switch.

### How to perform the set-up:



During the SET-UP, the safety devices are ignored, keep away and stop anyone from approaching the automation system until the end of the procedure



The SET-UP MUST be performed:

- with the mains power switched on
- with the automation system functioning automatically
- with the STOP/EMER inputs not active

1. Select parameter  $\text{E}_L$  in Basic Programming, the display shows --.:
2. Keep the buttons pressed  $+$  and  $-$  around 3 seconds. When  $\square$  appears flashing, release the buttons. The beam begins to close and stops when it reaches the stop.
3.  $\square$  flashes on the display. The beam remains in the closure position for a couple of seconds.
4.  $\square$  flashes on the display. The beam begins to open and stops when it reaches the stop.
5. The procedure has come to an end and the display shows the status of the open automation system ( $\square$ ).

## 9. PUTTING INTO SERVICE

### 9.1 FINAL CHECKS

1. If foot traffic cannot be excluded, check that the forces generated by the beam fall within the limits permitted by the standard. Use an impact force tester in accordance with standards EN 12453 and EN 12445. For non-EU countries, of there are no specific local regulations, the force must be less than 150 N. Check that the maximum force required to move the beam by hand is less than 220 N.
2. Check the automation system is working properly with all the devices installed.

### 9.2 FINAL OPERATIONS

1. Fit the upper cover (see the relative section).
2.  43 Apply the notice supplied warning against the risk of cutting, crushing or the loss of fingers or a hand between the beam and the body of the barrier.



The indication of the RISK must be visible even with the beam closed.

3. Highlight all areas with adequate warning signs in which there are still residual risks, even if all possible safety measures having been adopted.
4. Exhibit the sign prohibiting foot traffic.
5. Place the "DANGER - AUTOMATIC MOVEMENT" sign where it is clearly visible. Place the EC marking on the barrier.



Use adhesive signs so as not to perforate the box.

6. Fill out the EC declaration of conformity and the system register.
7. Give the EC Declaration, the system register with the maintenance plan and the instructions for use of the automation system to the system owner/operator.

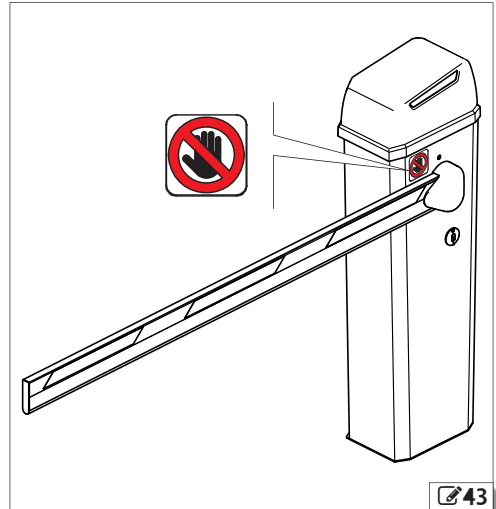

## 10. ACCESSORIES



The installation must comply with Standards EN 12453 and EN 12445.

When working in the box there are risks of cutting, shearing, crushing hands due to the presence of moving parts. Until the installation is completed, the partially installed barrier must always be left blocked and with the door and upper lid always closed to prevent access to the electronic parts and the moving mechanical parts. Never install the beam before fixing the barrier body and checking it. Until the installation is complete never leave the barrier unguarded with the beam fitted. Mark off the work site and prohibit access/transit. If installation is outside, it must be done in good weather without rain or gusts of wind. If it is raining, an adequate shelter for the barrier must be made until the mechanical and electronic installation is complete.

Never manage the barrier by holding the board holder.

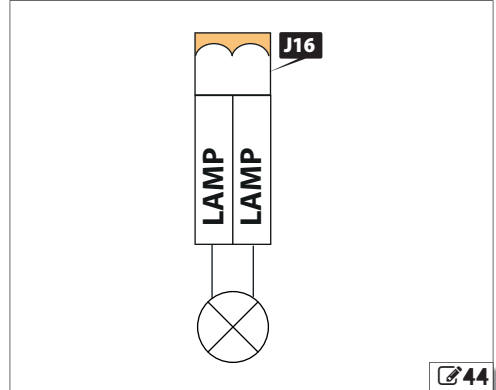

44

### 10.1 24V FLASHING LIGHT

The flashing light indicates that the automation is moving.



Install the flashing light in an easily visible position.

1. (44) Connect the flashing light to terminal clamp J16 (3 W max).
2. If required, set the preflash (PF Advanced programming)
3. Check that the device is working properly.

### 10.2 EMERGENCY BATTERY XBAT 24

XBAT 24 ensures that the automation system is powered if there is a mains power supply failure. The number of cycles that can be carried out with the battery depends on various factors (state of battery charge, time elapsing since the power outage, room temperature etc.).



Recharge the battery before starting the system. The full charging cycle of the XBAT 24 battery is 72 hours.

1. (45) Positioning the battery
2. Connect the battery to clamp J8 on the board
3. Set battery operation (bF Advanced programming)



Disconnect the emergency battery if the automation system is taken out of use.

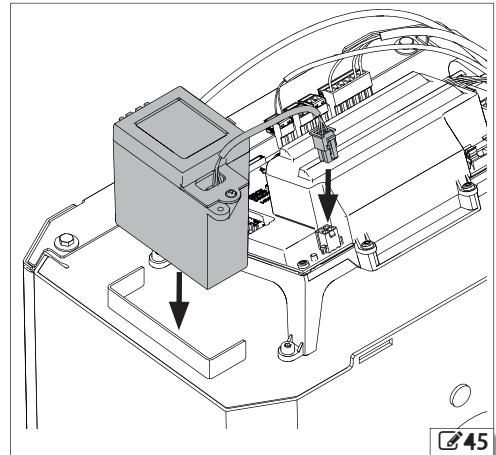

45

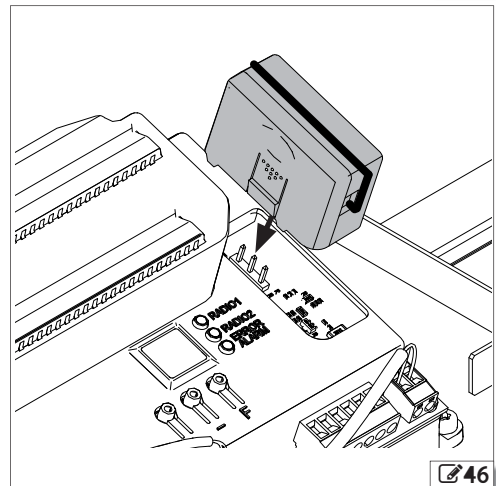

46

### 10.3 RADIO MODULE XF

E614 is fitted with an OMNIDEC integrated two channel decoding system that can memorise, via the XF radio module, FAAC radio remote controls that use the following types of radio code: SLH/SLH LR, LC/RC, DS.



The three types of radio codes can coexist simultaneously. A maximum of 256 codes can be memorised. The codes memorised act as an OPEN or CLOSE command. The remote controls and the XF radio module must have the same frequency. When memorising the codes, keep the remote control approximately one meter from the XF radio module.

1.  46 Insert the XF radio module in the connector J3 paying attention to the insertion direction (imm.xx).
2. Memorise the remote controls.



Ensure that there are no obstacles (persons or things) while the automation is moving.

#### SLH/SLH LR - MEMORISING THE FIRST REMOTE CONTROL

1. Press and keep pressed the + key (OPEN programming) or - (CLOSE programming). After pressing the button for about 5 seconds, the corresponding radio LED (DL4 or DL5) will start to flash to indicate that the radio code learning phase has started.
2. Release the button. From this moment E614 stays in the learning phase for around 20 secs.
3. Press and hold down buttons P1 and P2 simultaneously on the SLH/SLH LR remote control (master version only). The LED on the remote control starts to flash.
4. Release both buttons; the LED on the remote control continues to flash.
5. Make sure that the LED DL4 or DL5 on the board is still flashing and press the button of the remote control that you wish to memorise for a few seconds (the LED becomes steady). Release the button of the remote control.
6. Press the same button that was used in the previous step twice in succession to complete the memorisation process. If the procedure was carried out correctly, B614 opens, if permitted by the operating mode that has been set.

#### SLH/SLH LR - MEMORISING OTHER REMOTE CONTROLS

1. Press and hold down buttons P1 and P2 simultaneously on the SLH/SLH LR remote control that has already been memorised (master version only). The LED on the remote control starts to flash.

2. Release both buttons; the LED on the remote control continues to flash.
3. Press and hold down the button that has already been memorised (the LED becomes steady).
4. Place the remote control that has already been memorised close to the remote control to be memorised (keeping the button in the previous step pressed).
5. Press the button of the remote control to be memorised and make sure that its LED flashes twice before going off, to indicate that the procedure was completed successfully.
6. Release all buttons.
7. Press the button used in step 5 twice in succession to complete the memorisation process for the new remote control. If the procedure was carried out correctly, the B614 will open the barrier, if permitted by the operating mode that has been set.

#### LC/RC - MEMORISING THE FIRST REMOTE CONTROL

1. Press and keep pressed the + key (OPEN programming) or - (CLOSE programming). After pressing the button for about 5 seconds, the corresponding radio LED (DL4 or DL5) will start to flash to indicate that the radio code learning phase has started.
2. Release the button, from this moment E614 stays in the learning phase for around 20 secs.
3. Make sure that the LED DL4 or DL5 on the board is still flashing and press the button of the LC/RC remote control that you wish to memorise for a few seconds (the LED becomes steady). The LED (DL4 or DL5) on the board goes on as a steady light for 1 sec to then start flashing again for another 20 seconds during which it is possible to memorise another remote control.
4. To memorise additional remote controls at a later stage, repeat the procedure from the beginning or carry out the remote memorisation procedure.

#### LC/RC - REMOTE CODE MEMORISATION PROCEDURE

Additional remote controls can be memorised remotely, i.e. without having to use the board directly, by using a remote control that has already been memorised.

1. Near the E614 press buttons P1 and P2 if the remote control already memorised (as OPEN or CLOSE at the same time). The LED of the remote control and LED DL4 or DL5 of the board begin to flash for 5 secs.
2. Release both the buttons then press the button already memorised within five seconds. From this moment E614 stays in the learning phase for around 20 secs.

3. Make sure that the LED DL4 or DL5 on the board is still flashing and press the button of the remote control that you wish to memorise. The LED (DL4 or DL5) on the board goes on as a steady light for 2 sec to then start flashing again for another 20 seconds during which it is possible to memorise another remote control.
4. Wait for LED DL4 or DL5 on the board to turn off before using the new remote control.

2. Release the - button. The LEDs turn off, indicating that the codes were deleted correctly.



## DS - MEMORISING REMOTE CONTROLS

1. Set the required ON/OFF combination of the 12 dip-switches on the DS remote control. Avoid setting all of them to ON or all of them to OFF.
2. Press and keep pressed the + key (OPEN programming) or - (CLOSE programming). After pressing the button for about 5 seconds, the corresponding radio LED (DL4 or DL5) will start to flash to indicate that the radio code learning phase has started.
3. Release the button, from this moment E614 stays in the learning phase for around 20 secs.
4. Make sure that the LED DL4 or DL5 on the board is still flashing and press the button of the DS remote control that you wish to memorise for a few seconds. The corresponding LED (DL4 or DL5) on the board will turn on with a steady light for 1 second and then turn off to indicate that the procedure was completed successfully.
5. To add different codes, repeat the procedure starting from point 1.
6. For additional remote controls, use the same ON/OFF combination for the 12 dip-switches on the remote control that has been memorised.

## DELETING REMOTE CONTROLS FROM MEMORY



This procedure cannot be reversed and cancels ALL the codes of the remote controls memorised both as OPEN and as CLOSE. The deletion procedure is only active in the barrier status display mode.

1. Press and hold down the - button.



- After holding LED DL5 down for approx 5 seconds it begins to flash slowly, after another 5 seconds flashing slowly and pressure maintained LEDs DL4 and DL5 begin to flash more quickly (beginning cancellation).
- At the end of the rapid flashing LEDs DL4 and DL5 come on and remain steady to confirm the successful cancellation of all the (OPEN and CLOSE) radio codes in the board.



### 10.4 BUS 2EASY DEVICES

This board has a BUS 2easy circuit for connecting BUS 2easy devices (photocells, control devices).

**i** If no BUS 2easy accessories are used, leave the BUS 2easy connector free. Do not bridge.

#### CONNECTION

**47** Connect any BUS 2easy devices (photocells and control devices) to terminal J3.

**i** The overall length of the BUS 2easy cables must not exceed 100 m.  
The BUS line does not require a matching polarity connection.

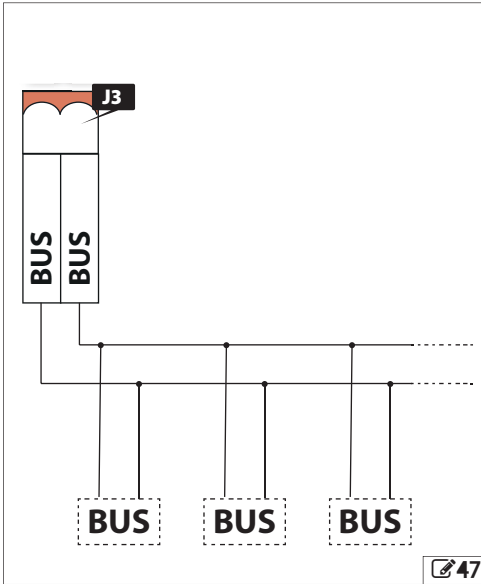

### BUS 2EASY PHOTOCELLS

Type of use:

Closing photocells	Active during closing	When an obstacle is detected, they stop the barrier and reopen it.
--------------------	-----------------------	--

Photocells used as pulse generators	Always active	When an obstacle is detected, they send an OPEN command
-------------------------------------	---------------	---

1. Assign an address to the BUS 2easy photocells (xx).

#### **11** Orienting the photocells

1 0 0 0	ON
1 0 0 1	
1 0 1 0	
1 0 1 1	
1 1 0 0	
1 1 1 0	
1 1 1 1	

Assign an address to each pair of photocells by setting the four DIP switches (DS1) on the transmitter and the corresponding receiver.

**i** The transmitter and receiver of a pair of photocells must have the same DIP switch settings.  
There must never be two or more pairs of photocells with the same DIP switch settings. If there is more than one pair of photocells with the same address, a conflict error is generated.

2. Register the BUS 2easy photocells (bu in basic programming).
3. Check the status of LEDs DL3 and DL7 (**11**).
4. Check that the photocells are operating correctly. When the barrier is moving, interrupt the beam with an obstacle and check the LEDs on the photocells, the status of the bus on the display and the automation system operate according to the type of photocell installed.

### CONTROL DEVICES

1. Position the DIP switches to assign the commands.

**i** Stop NC also generates a stop when the device is disconnected. A command (e.g.: OPEN A\_1) must be used on only one of the connected devices.

## 12 Addressing control devices

0 0 0 0	Open A_1
0 0 0 1	Open A_2
0 0 1 0	Open A_3
0 0 1 1	Open A_4
0 1 0 0	Open A_5
0 1 0 1	Stop
0 1 1 0	Stop NC_1
0 1 1 1	Stop NC_2
1 0 0 0	Close
1 0 0 1	Open B_1
1 0 1 0	Open B_2
1 0 1 1	Open B_3
1 1 0 0	Open B_4
1 1 0 1	Open B_5
1 1 1 0	/
1 1 1 1	/



1 command  
DIP switch 5 =  
0 (OFF)

0 0 0 0	Open A_1	Open B_1
0 0 0 1	Open A_1	Open B_2
0 0 1 0	Open A_1	Stop
0 0 1 1	Open A_1	Close
0 1 0 0	Open A_2	Open B_1
0 1 0 1	Open A_2	Open B_2
0 1 1 0	Open A_2	Stop
0 1 1 1	Open A_2	Close
1 0 0 0	Open A_3	Open B_3
1 0 0 1	Open A_3	Open B_4
1 0 1 0	Open A_3	StopNC_1
1 0 1 1	Open A_3	Close
1 1 0 0	Open A_4	Open B_3
1 1 0 1	Open A_4	Open B_4
1 1 1 0	Open A_4	StopNC_2
1 1 1 1	Open A_4	Close



2 commands  
DIP switch 5 =  
1 (ON)

- Register the BUS 2easy control devices (Basic Programming).
- Check the status of LEDs DL3 and DL7.
- Check that the devices are working properly. Use the controls to make the barrier move. Check the LEDs on the devices, the status of the bus on the display and make sure that the automation system operates according to the type of device installed.

### BUS 2EASY DEVICE REGISTRATION

Registration is required:

- When the automation system is first started or after the board has been replaced.
- Following any changes (addition, replacement or removal) to the BUS 2easy devices.

### Registration procedure:

- Select parameter **bu** in basic programming. When **F** is released, the display shows the status of the BUS 2easy devices.
- Press and hold the **+** and **-** buttons simultaneously for at least 5 seconds until **U** appears (the display flashes during this time). Registration has been completed.
- Release the **+** and **-** buttons. The display indicates the status of the BUS 2easy devices.
- Check the status of the LEDs on the board:

#### LED DL7 (Red) - BUS 2easy devices

- At least one device is engaged/active
- No device is engaged/active

#### LED DL3 (Green) - BUS 2easy line

- Line monitoring. LED always on (off with board in Sleep mode)
- Line short-circuited
- Device error: check the ERROR LED

### Registered device verification procedure:

- Select parameter **bu** in basic programming. After registering one or more devices, **bu** displays segment 13 on.
- Press and hold the **+** button and keep it pressed; the segments relative to the registered devices will come on. Each segment of the display corresponds to a type of device:

1	Open A control device
2	Open B control device
3	Closing photocells
4	Photocells for Open impulse
5	Not used
6	Close control device
7	Not used
8	Stop control device
9	Closing edge
10	Not used
11	Not used
12	Opening edge
13	BUS 2easy status
14	Not used

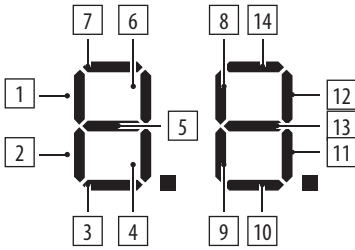

no	No device registered
cc	BUS 2easy line short-circuited
E-	BUS 2easy line error

**RECTANGULAR BEAM LIGHT KIT**

Remove the plug.  
Insert the cable gland for the light kit.

Work in progress

**10.5 ROUND BEAM LIGHT KIT**

Work in progress

**10.6 INTEGRATED FLASHING LIGHT**

Work in progress

**10.7 BEAM JOINT KIT**

**RISKS**



**PERSONAL PROTECTIVE EQUIPMENT**



Follow the assembly instructions provided with the product respecting all the safety precautions indicated in this manual.

- !** The installation of a jointed beam must take the specific risks into consideration:
- IMPACT on the horizontal section of the beam, when the beam is open
  - CRUSHING in the jointed area, when the beam is moving.
  - Do not use joint to limit the height of the vehicles passing.
  - Indicate the maximum height of the vehicles considering the height of the beam itself.
  - Apply a danger of crushing sticker on the beam in the jointed area.
  - Check the integrity of the wire during the half-yearly scheduled maintenance.

Vite fissaggio siepe Nr.3 M4 (XVT18B10140Z): 3Nm

Vite fissaggio piedino Nr.2 M5 (701008): 6Nm

## 10.8 HEDGE

Follow the assembly instructions provided with the product respecting all the safety precautions indicated in this manual.

 Check the fixing with the indicated tightening torque.

## 10.9 FOOT

Follow the assembly instructions provided with the product respecting all the safety precautions indicated in this manual.- Check the fixing with the indicated tightening torque.

- Check the lower protection is present and is in good condition.
- You should install a beeper or similar to indicate the beam is closing.
- Apply the reflector on the stem.

 On the rectangular beam, it is not possible to install the foot when there are lights on the beam.

## 10.10 FORK

Follow the assembly instructions provided with the product respecting all the safety precautions indicated in this manual.

-  - Check the fixing with the indicated tightening torque.
- You should install a beeper or similar to indicate the beam is closing.
  - Provide for a clearance area or signals to prevent pedestrians being knocked. The area must be adequately lit.

1 Adjustable foot

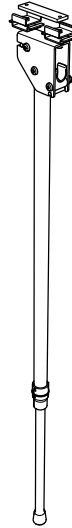

2 Adjustable fork

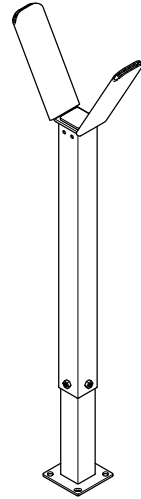

3 Hedge kit



4 Beam light kit



5 XF

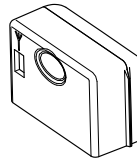

6 XBAT 24

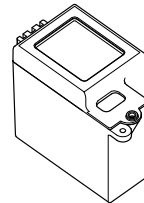

7 Head light kit

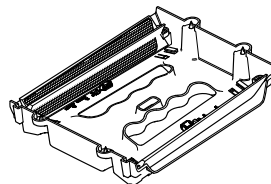

8 Joint kit

## 11. MASTER-SLAVE

( 48) The Master-Slave configuration makes it possible to install two counterposed barriers with synchronous movement.

When programming one barrier must be defined as Master and the other as Slave. The Master barrier manages all the controls and movements.

The control devices and any external loops must be connected to the Master barrier.

Each barrier must be programmed on the basis of the length and configuration of the beam. The functioning logic must only be programmed on the Master board. The anticrushing function is active on each barrier and commands the inversion of both.

### CONNECTION

1. Connect the barrier with BUS 2easy polarised connection ( 49).
2. Connect the devices (see § ). The inputs for the command devices and any external loop are inhibited on the Slave board.

Connections	Master	Slave
Power supply	✓	✓
Motor	✓	✓
Encoder	✓	✓
Head lighting	✓	✓
Beam lights	✓	✓
Control devices	✓	✗
Loop	✓	✗
Outputs	✓	✓
Flashing light	✓	✓

3. The BUS 2easy devices can be connected to the Master or to the Slave board. The devices must be registered on the Master barrier.

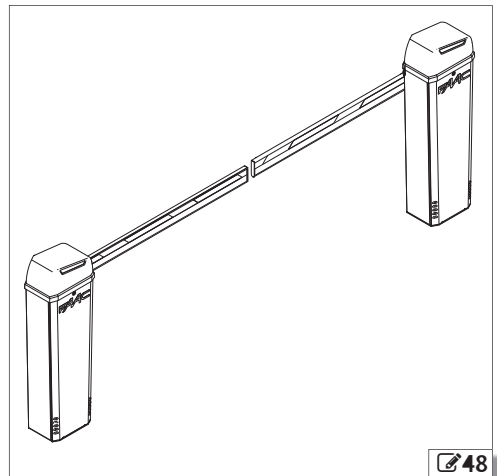

48

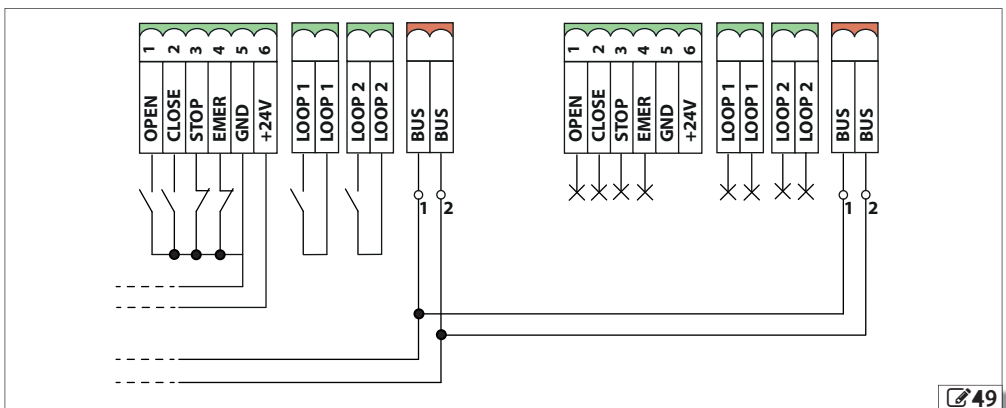

49

## SLAVE BARRIER CONFIGURATION

1. Power Slave barrier The board turns on. The display reads in sequence:
  - firmware version (2 digits separated by a dot)
  -  flashing if a set-up or the automation status is requested
2. Access the Basic programming and set:
  - $\epsilon F$  depending on the beam configuration and length
  - $\square \square = SL$  for configuring the board as Slave.
3. Check the status of the LEDs on the board:

### LED DL7 (Red)



Master-Slave synchronisation absent or the line is short circuited.

### LED DL3 (Green)



Master-Slave synchronisation present.

4. Check the direction of travel (see § 12.2). The barrier must not be in manual functioning mode.
5. Start up (see § 8).



During the set-up the Master board controls the Slave board and the two beams move with a synchronous movement.

## 12. DIAGNOSTICS

### 12.1 LEDS CHECK

LED	STATUS	IDLE
DL1 BUS	● active ○ not active	○
DL2 BUS MON	See device description BUS Zeasy	●
DL3 RADIO1	● active ○ not active	○
DL4 RADIO2	● active ○ not active	○
DL5 Error/alarm "ERROR"	● active ○ not active	○
DL8 EMER	● not active ○ active	●
DL9 STOP	● not active ○ active	●
DL10 CLOSE	● active ○ not active	○
DL11 OPEN	● active ○ not active	○
DL12 LOOP1	● active ○ not active	○
DL13 LOOP2	● active ○ not active	○



In Master-Slave configuration see § 11.

### 12.2 DIRECTION OF MOVEMENT CHECK

1. Select parameter  $\overline{M}$  in the Basic programming. The display shows --.
2. Keep the + button pressed. The display shows  $\overline{OP}$  and the barrier opens.
3. Keep the - button pressed. The display shows  $\overline{CL}$  and the barrier closes.
4. If the conditions in points 2 and 3 are not respected, invert the motor wires.

### 12.3 ENCODER OPERATION CHECK

1. Select parameter  $\overline{M}$  in Basic Programming, the display shows --.
2. Keep the + button pressed. The display shows  $\overline{OP}$  and the barrier opens. The flashing point between the two letters indicates that the encoder is operating correctly.
3. Keep the - button pressed. The display shows  $\overline{CL}$  and the barrier closes. The flashing point between the two letters indicates that the encoder is operating correctly.

### 12.4 AUTOMATION SYSTEM STATUS CHECK

The E614 display if not in the programming, shows a code indicating the status the automation is in:

00	Closed
01	Open
02	Stationary then opens
03	Stationary then closes
04	In pause mode
05	Opening
06	Closing
07	Failsafe underway
08	BUS Zeasy device verification in progress
09	Pre-flashing and then opens
10	Pre-flashing and then closes
11	Opening in Emergency

### 12.5 CHECK FIRMWARE VERSION

When the display of the E614 is switched on, it shows the following in succession:

- firmware version (2 digits separated by a point)
- automation system status

### 12.6 CHECK OF THE REGISTERED BUS ZEASY DEVICES

1. Select parameter  $\overline{BU}$  in Basic programming.
2. Press the button + and keep it pressed; the segments relative to the registered devices will come on (see  $\overline{48}$ ).

### 12.7 MAINTENANCE REQUEST - CYCLE COUNTER

Work in progress

## 13. MAINTENANCE

### RISKS



### PERSONAL PROTECTIVE EQUIPMENT



Always shut off the power supply before performing any maintenance operations. If the disconnect switch is not in view, apply a warning sign stating "WARNING - Maintenance in Progress". Restore the power supply only after finishing any maintenance work and restoring the area to normal.

Do not remove the board cover. No maintenance requires the removal of the cover.



The barrier must not be left released. If the barrier is put out of order for a long time, the beam needs to be removed.

Maintenance must be performed by the installer or a maintenance technician.

Follow all safety recommendations and instructions given in this manual.

Mark off the work site and prohibit access/transit. Do not leave the work site unattended.

The work area must be kept tidy and cleared after maintenance has been completed.

Before starting work, wait for any hot components to cool down.

Do not make any modifications to the original components.

FAAC S.p.A. shall bear no liability for damage or injury due to components which have been modified or otherwise tampered with.



The warranty shall be forfeited in the event of tampering with components.

Only use original FAAC spare parts.

### 13.1 ROUTINE MAINTENANCE

The **Scheduled maintenance** lists as pure approximation and intended as guidelines that are not exhaustive, the periodic operations for keeping the automation system efficient and safe. The installer/machine manufacturer is responsible for drawing up the maintenance plan for the automation system, supplementing this list or modifying the maintenance operations on the basis of the machine characteristics.

#### 13 Routine maintenance

If the tests listed below turn up conditions that are other than expected, repair or restoration is necessary. The plant must not be put back into operation until all the safety precautions specified in this manual and in the documentation of all the other components installed have been complied with.

Operations	Frequency/months
<b>Structures</b>	
Check the plinth and built/fenced parts around the automation system: make sure there is no damage, cracking, breaks or subsidence.	12
Check the area the beam moves in: make sure there are no objects/deposits that reduce the uncluttered safety areas and obstacles to the movement of the beam such as branches, overhead wires etc.	12
Ensure that there are no sharp protrusions which could represent a perforation or hooking hazard.	12
<b>Barrier</b>	
Check the fixing of the bearing box to the foundation plate.	6
Check the barrier and its fixings: integrity, absence of deformation, rust etc.	12
Check that screws and bolts are correctly tightened.	
Check the integrity of the actuator and that it is fixed properly.	12
Check the integrity of the beam and that it is fixed properly.	12
Check the presence and integrity of the reflectors on the beam and all the other signs and markings necessary.	6
Check the integrity and proper fixing of the spring and tie rods.	12
Check the configuration and the balancing of the barrier.	12
Check the integrity, proper functioning and adjustment of the limit switch.	12
Check the integrity of all the cables, cable glands and junction boxes.	12
Check that it is irreversible.	12
Clean the actuator and the bearing box.	12
Do a general cleaning of the barrier manoeuvre area.	12



<b>Electronic equipment</b>	
Check the integrity of the upper cover and the plastic electronic board protection.	12
Check that the connectors and wiring are intact.	12
Check that the earth connections are intact.	12
Check that there are no signs of overheating, burning etc. of electronic components.	12
Check the operation of the circuit breaker and RCD.	12
<b>Control devices</b>	
Check that the installed devices and remote controls are in good condition and that they operate correctly.	12
<b>Deformable edges</b>	
Check that they are intact and correctly fastened.	12
<b>Photocells</b>	
Check condition, fastening and correct operation.	6
Check the posts, ensuring that they are intact, correctly fastened and free of deformation etc.	6
<b>Flashing light</b>	
Check condition, fastening and correct operation.	12
<b>Access control</b>	
Check the proper opening of the barrier only with authorised user recognition.	12
<b>Hedge</b>	
Check: the integrity and fixing of the beam.	6
<b>Foot</b>	
Check: the integrity and fixing of the beam.	6
Check the presence and integrity of the reflectors on the foot and all the other signs and markings necessary.	6
Check the presence and integrity of the lower foot guard.	6
<b>Fork</b>	
Check that they are intact and correctly fastened.	6
Check the presence and integrity of all the signs and markings necessary.	6
<b>Jointed beam</b>	
Check that they are intact and correctly fastened.	6
Check the integrity of the wire and the relative signs (max height allowed, risk of crushing in the beam joint).	6
<b>Complete automation system</b>	
Check that the automation system operates correctly, following the set logic, when using the various control devices.	12
Check the proper fluid, smooth movement of the beam without strange noises.	12
Check the correct speed during opening and closing and the respect for the intended slow downs.	12
Check the correct functioning of the manual release: when the release is activated it must only be possible to move the beam manually.	6
Check the presence of the lock cover.	

Check that the maximum force required to move the beam by hand is less than 220 N.	6
Check that the encoder is working properly.	6
Check that each pair of photocells is working correctly.	6
Check there is no optical/light interference between the photocells.	6
If the pedestrian transit cannot be excluded, check the force limitation curve (EN 12453 and EN 12445 standards). For non-EU countries, if there are no specific local regulations, the force must be less than 150 N. ??	6
Check that all necessary signage and warnings are present, intact and legible: residual risks, exclusive use etc.	12
Check the presence, integrity, legibility of the EC marking covering the automation system and the DANGER AUTOMATIC MOVEMENT warning sign	12

 **14** Periodic replacements

Component	Work cycle periodicity
Spring	200000
Electromechanical actuator	500000

**13.2 SPRING REPLACEMENT**

Work in progress

**13.3 REPLACEMENT OF THE ELECTROMECHANICAL ACTUATOR**

Work in progress

## 13.4 FUSE REPLACEMENT

1.  Remove the fuse F1 cover by gently prising it off with a screwdriver.
2. Dismantle the fuse
3. Assemble the new fuse.
4. Refit the fuse cover.



Only use a T 2.5A (delayed) fuse.

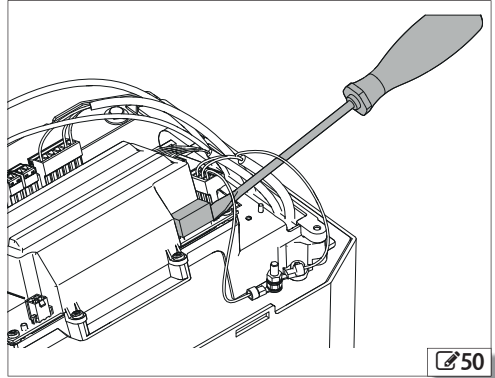

 50

## 13.5 OPERATIONAL PROBLEMS

### 15 Troubleshooting

CONDITION	FINDING SOLUTIONS
The barrier does not perform the SET-UP	check the automation system is not released check there is power
The barrier does NOT OPEN	check the motor and encoder connection
The barrier CLOSES rather than OPENING and vice versa.	invert the phases in the motor connection and perform a SET-UP
The barrier makes very slow movements	check the force set check the balancing of the beam check the parameter cF has been set in accordance with the beam length if the barrier is being battery operated make sure the battery is charged.
The barrier does NOT OPEN	check the automation is not released check the motor direction of travel
The barrier does NOT CLOSE	check the automation is not released check the motor direction of travel Check the LED status of the controls, loops, safety devices and EMER are not active
The barrier does NOT OPEN and does NOT CLOSE	check the automation is not released Check the status of the STOP LED is not active check the motor and encoder connection

## 14. INSTRUCTIONS FOR USE

It is the responsibility of the machine installer/manufacturer to draft the user instructions of the automation in accordance with the Machinery Directive, including all the required information and instructions based on the characteristics of the automation.

The guidelines below, which are purely indicative and in no way exhaustive, help the installer draft the user instructions.



The installer must provide the owner/operator of the automation with the EC Declaration, the system Logbook with the maintenance schedule and the user instructions of the automation.

The installer must inform the owner/operator of any residual risks and the intended use and ways in which the machine should not be used.

The owner is responsible for operating the automation and must:

- comply with all User instructions provided by the installer/maintenance technician and the Safety recommendations
- keep the user instructions
- have the maintenance schedule implemented
- keep the system Logbook, which must be completed by the maintenance technician at the end of all servicing

### 14.1 SAFETY RECOMMENDATIONS

The plants made with FAAC buried actuators B614 series are intended for vehicular traffic.

The user must be in good physical and mental health and be aware of and responsible for the dangers which use of the product can lead to.



- Do not use the automation system when the area of operation is not free of persons, animals or objects.
- Do not remain in or walk/drive through the area of operation of the automation system while it is moving.
- Do not allow children to approach or play in the area of operation of the automation system.
- Do not try to prevent the movement of the automation system.

Do not climb or catch on to the beam or let yourself be pulled by it.

- Do not allow the devices to be used by anyone who is not specifically authorised and trained to do so.
- Do not allow the devices to be controlled by children

or persons with mental and physical deficiencies unless they are supervised by an adult who is responsible for their safety.

- Do not use the automation system in the presence of faults which could compromise safety.
- Do not expose the automation system to corrosive chemical or atmospheric agents; do not expose the actuator to corrosive chemical or atmospheric agents.
- Do not perform any work on the components of the automation system.

Risk of cutting, crushing or losing fingers or a hand between the beam and the box. Do not approach the barrier, do not put your hands in the danger area during movement.

### 14.2 EMERGENCY USE

In any case the beam is not behaving properly, in emergencies or if there is a fault, turn off the electricity supply to the automation system and disconnect the buffer batteries if there are any. If the conditions exist for the manual movement of the beam safely, use the MANUAL FUNCTION; otherwise keep the automation out of order until the repair or restoration.

In the case of a breakdown, the automation system must be reset/repared exclusively by the INSTALLER/ MAINTENANCE TECHNICIAN



For atmospheric events outside the resistance to wind limits indicated in the table in situations of alert it is necessary to put the barrier out of service with closed, locked beam and ask for the installation engineer to dismantle the beam.

## 14.3 MANUAL OPERATION



- Performing the release manoeuvre when there is no electrical power.
- Performing the release manoeuvre only when the beam is at a standstill.
- During manual handling, accompany the beam slowly for the entire stroke. Do not let the beam travel freely.
- Do not leave the barrier unblocked: after carrying out the manual movement, restore automatic operation.

### RELEASE PROCEDURE



1.  51 Open the lock cover. Insert the key and turn it once anticlockwise until it stops (1).
2. Move the barrier manually.
3. Restore the operation.

### OPERATION RESTORATION



1.  51 Insert the key and turn it twice clockwise until it stops (2).
2. Check that manual movement is inhibited.
3. Remove the key and close the cover.

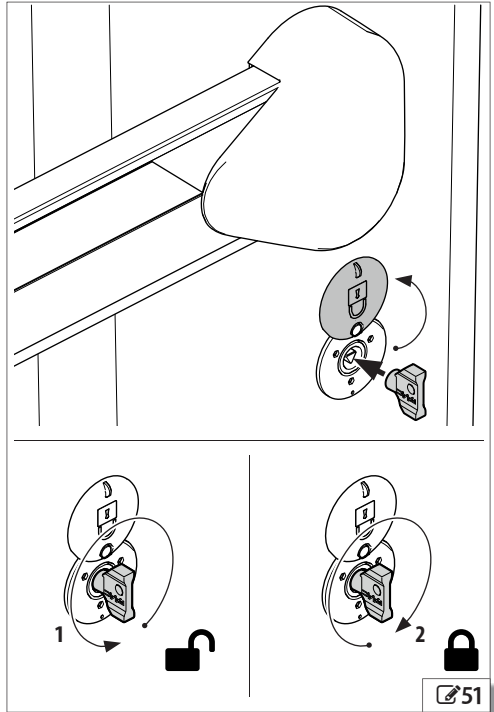

1 Foundation for barrier in maximum configuration

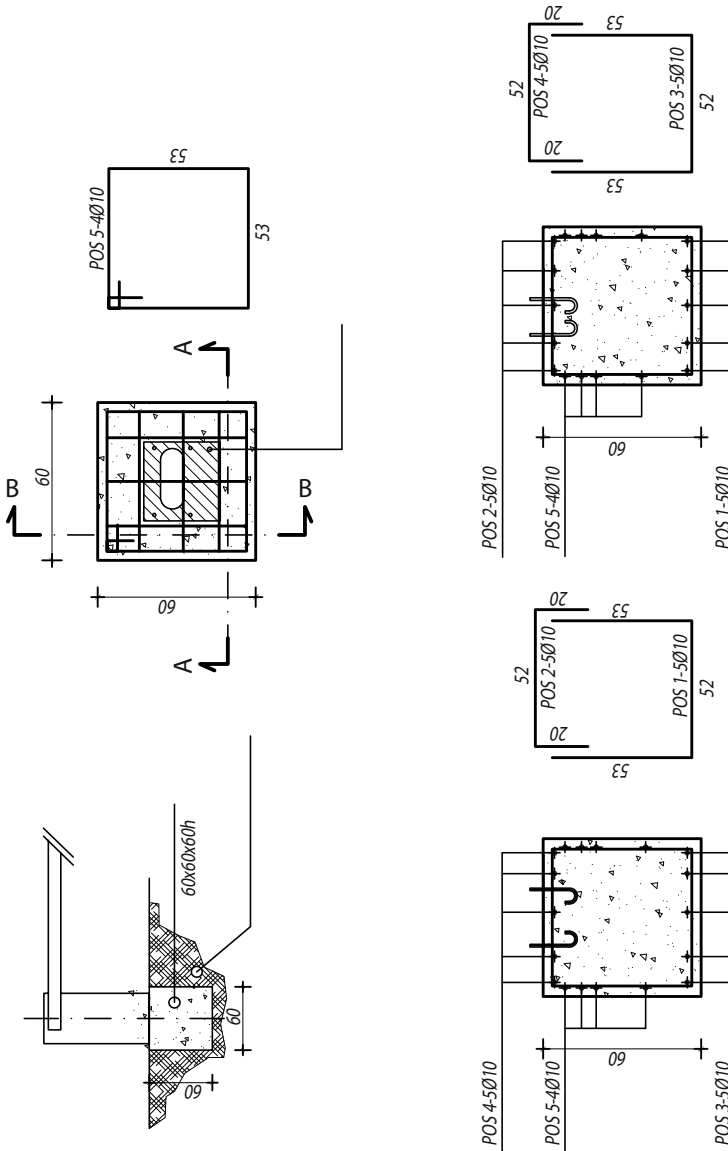

## 2 Balancing system

### 16 Rectangular beam balancing



beam length	max 2.0 m	2.0 ... 2.85 m	2.85 ... 3.35 m	3.35 ... 3.85 m	3.85 ... 4.35 m	4.35 ... 4.85 m
beam (no accessory)	☺ 1 B	☺ 2 B	☺ 3 A	☺☺ 5 A	☺☺ 5 A	☺☺ 4 A
beam and lights	☺ 1 B	☺ 2 B	☺ 4 A	☺☺ 5 A	☺☺ 3 A	☺☺ 4 A
beam and hedge	☺ 1 B	☺ 3 A	☺ 4 A	☺☺ 3 A	☺☺ 3 A	☺☺ 4 A
beam and foot	☺ 2 B	☺ 4 A	☺ 5 A	☺☺ 3 A	☺☺ 4 A	☺☺ 4 A
beam, hedge and foot	☺ 2 B	☺ 4 A	☺ 5 A	☺☺ 4 A	☺☺ 4 A	☺☺ 5 A

### 17 Round beam S balancing



beam length	max 2.0 m	max 3.20 m	3.20 ... 3.70 m	3.70 ... 4.20 m	4.20 ... 4.70 m	4.70 ... 5.20 m
beam (no accessory)	☺☺ 3 A	☺☺ 3 A	☺☺ 4 A	☺☺ 5 A	☺☺ 4 A	☺☺ 4 A
beam and lights	☺☺ 3 A	☺☺ 3 A	☺☺ 4 A	☺☺ 3 A	☺☺ 4 A	☺☺ 5 A
beam and hedge	☺☺ 4 A	☺☺ 4 A	☺☺ 5 A	☺☺ 4 A	☺☺ 5 A	☺☺ 5 A
beam and foot	☺☺ 4 A	☺☺ 4 A	☺☺ 5 A	☺☺ 4 A	☺☺ 4 A	☺☺ 5 A
beam, lights and foot	☺☺ 4 A	☺☺ 4 A	☺☺ 3 A	☺☺ 4 A	☺☺ 5 A	☺☺ 5 A
beam, hedge and foot	☺☺ 3 A	☺☺ 3 A	☺☺ 3 A	☺☺ 5 A	☺☺ 5 A	-
beam, lights, hedge and foot	☺☺ 3 A	☺☺ 3 A	☺☺ 3 A	☺☺ 5 A	-	-

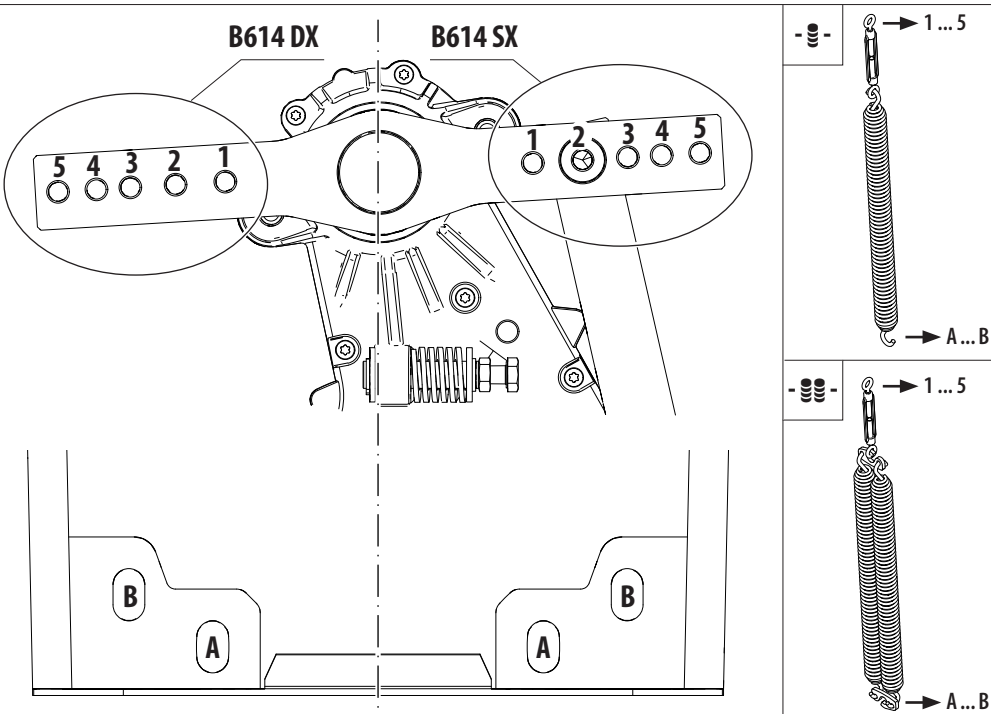



FAAC S.p.A. Soc. Unipersonale  
Via Calari, 10 - 40069 Zola Predosa BOLOGNA - ITALY  
Tel. +39 051 61724 - Fax +39 051 758518  
[www.faac.it](http://www.faac.it) - [www.faacgroup.com](http://www.faacgroup.com)