

AIRSLIDE



FAAC

EN16005:2012



energy  saving



FAAC S.p.A. Soc. Unipersonale
Via Calari, 10 - 40069 Zola Predosa BOLOGNA - ITALY
Tel. +39 051 61724 - Fax +39 051 758518
www.faac.it - www.faacgroup.com

© Copyright FAAC SpA since 2017. All rights reserved.

No part of this manual may be reproduced, archived, distributed to third parties nor copied in any other way, in any format and with any means, be it electronic, mechanical or by photocopying, without prior written authorisation by FAAC SpA

All names and trademarks mentioned are the property of their respective manufacturers.

Customers may make copies exclusively for their own use.

This manual was published in 2017.

EU DECLARATION OF CONFORMITY

The Manufacturer

Company name: FAAC S.p.A. Soc. Unipersonale
Address: Via Calari, 10 - 40069 Zola Predosa BOLOGNA - ITALY

hereby declares on his own responsibility that the following products:

Description: Air curtain for automatic entry
Model: AIRSLIDE KIT ; AIRSLIDE PA

comply with the following applicable EU legislations:

EMC Directive 2014/30/EU
 Directive ROHS 2 2011/65/EU
 LVD Directive 2014/35/EU

Furthermore, the following harmonised standards have been applied:

EN 61000-6-2:2005
 EN 61000-6-3:2007+A1:2011
 EN60335-2-80 : 2003 + A1 : 2004 + A2 : 2009

Bologna, Italy 08-09-2017

A. Marcellan CEO

EU DECLARATION OF CONFORMITY

The Manufacturer

Company name: FAAC S.p.A. Soc. Unipersonale
Address: Via Calari, 10 - 40069 Zola Predosa BOLOGNA - ITALY

hereby declares on his own responsibility that the following products:

Description: Automatic entry with integrated air curtain
Model: AIRSLIDE CS

comply with the following applicable EU legislations:

EMC Directive 2014/30/EU
 Directive ROHS 2 2011/65/EU

Furthermore, the following harmonised standards have been applied:

EN 61000-6-2:2005
 EN 61000-6-3:2007+A1:2011

Bologna, Italy 08-09-2017

A. Marcellan CEO



EC DECLARATION OF CONFORMITY OF A MACHINE

(2006/42/EC ANNEX II P.1, A)

Manufacturer and person authorised to compile the technical file

Company name: FAAC S.p.A. Soc. Unipersonale

Address: Via Calari, 10 - 40069 Zola Predosa BOLOGNA - ITALY

hereby declares on his own responsibility that the following products:

Description: Automatic entry with integrated air curtain

Model: AIRSLIDE CS

complies with the following applicable EU legislations:

Machinery Directive 2006/42/EC (including all applicable amendments)

and that the technical file has been compiled in compliance with part A of Annex VII.

Furthermore, the following harmonised standards have been applied:

EN 16005:2012

EN ISO 12100:2010

EN 60335-2-103:2015

EN 13849-1:2015 PL "c" CAT. 3

EN 13849-2:2012

Bologna, Italy 08-09-2017

A. Marcellan CEO



CONTENTS

EU Declaration of conformity 3
 EU Declaration of conformity 3
 EC Declaration of conformity of a machine 4

1. INTRODUCTION TO THE MANUAL 6

1.1 Safety recommendations 6
 Safety of the installer/maintenance technician 6
 Workplace safety 6
 User safety 6

1.2 Meaning of the symbols used 7

2. AUTOMATION AIRSLIDE 9

2.1 Intended use 9
 Limitations for use 9

2.2 Unauthorised use 9

2.3 Technical specifications AIRSLIDE 10
 AirSlide serial number and rating label 10
 AIRSLIDE Components 11

2.4 Types of system supplied 12
 Installation according to the type of system supplied 12

3. INSPECTION AND PREPARATION 13

3.1 Preliminary inspection 13

3.2 Arrangement of electrical cables 13

4. TRANSPORT AND RECEIPT OF THE GOODS 14

4.1 Handle packages 14

4.2 Unpack and Handle 14

5. CUTTING THE PROFILES 15

6. ASSEMBLING THE HEAD SECTION 16

6.1 Electric fan module and plate with case for E1AS board 16

6.2 LOADING AND STRESSES BORNE BY ANCHORS 29

6.3 PERMISSIBLE SUBSTRATES 30

6.4 SUBSTRATE CONDITION 30

6.5 MINIMUM ANCHOR DISTANCES FROM EDGES 31

7. ELECTRONIC INSTALLATION 32

7.1 Plate and E1AS board 32

7.2 Terminal boards and connectors 33
 DIP SWITCH SW1 - SW2 34
 DIP SWITCH SW4 34
 J5 - USB Port 34

7.3 E1AS Electronic board LEDs 35

7.4 J1 - INPUTS 36

7.5 J2 INTERCOM 36

7.6 J7 - MOTOR INPUTS 37

7.7 J5 - Mains power supply 37

7.8 BUTTONS SW5 and SW6 37

7.9 DIP SWITCHES SW1 and SW2 37

7.10 DIP SWITCHES SW3 and SW4 37

7.11 J8 USB INPUT 37

7.12 E1AS board operation 37

7.13 Input J1 wiring configurations 39

7.14 3 position switch 40

TABLES

 **1** Symbols: notes and warnings on the instructions 7

 **2** Symbols: tools (type and size) 7

 **3** Symbols: safety signs and symbols (EN ISO 7010) 8

 **4** Symbols: Personal Protective Equipment 8

 **5** Symbols: markings on packaging 8

 **6** Symbols: markings on product 8

 **7** Technical specifications 10

 **8** LEDs on the board 35

1. INTRODUCTION TO THE MANUAL

The instructions manual provides the correct procedures and requirements to be complied with for installation and operation of the system in safe conditions.



Carefully read and comply with all the instructions before starting any activity on the product.
Keep these instructions for future reference.



Unless otherwise specified, the measurements provided in the instructions are in mm.

In writing the instructions manual, due account was taken of the results of the risk assessment conducted by the manufacturer on the entire life cycle of the automation in order to implement effective risk reduction.

The following stages of the life cycle of the automation were considered:

- Consignment reception/handling
- Assembly and installation
- Setting up and commissioning
- Operation
- Maintenance / addressing any failures
- Disposal at the end of the product's life.

The sources of risk arising from installation and use of the automation were taken into account:

- Risks for the installer/maintenance technician (technical personnel)
- Risks for the user of the automation
- Risks for the product's integrity (damage)

1.1 SAFETY RECOMMENDATIONS

The installer/maintenance technician is responsible for the installation/testing of the system and for filling in the system's Register.

SAFETY OF THE INSTALLER/MAINTENANCE TECHNICIAN



Installation must be performed in compliance with Standards currently in force. The installer's safety is connected to environmental and operative conditions that reduce the risks of accidents and severe damage to a minimum.

It should be remarked that most accidents occurring in the workplace are caused by failure to comply with and monitor the most basic and fundamental safety and prevention rules.

The installer/maintenance technician must prove or declare to possess the technical-professional proficiency to perform installation, testing and maintenance activities according to the requirements of these instructions. He or she is bound to read and comply with the instructions manual.

Incorrect installation and/or incorrect use of the product might cause serious harm to people.

Perform installation and other activities adhering to the sequences provided in the instructions manual.

Always comply with all the requirements contained in the instructions and warning tables at the beginning of the paragraphs.

Do not modify the components of the automation in any way.

Only the installer and/or maintenance technician is authorised to open the automation casing.



FAAC disclaims any liability regarding the safety and proper operation of the automation if non-original FAAC components are used.
FAAC supplies a system register form with the AIRSLIDE CS.

WORKPLACE SAFETY



The installer/maintenance technician must be in good psycho-physical conditions, aware of and responsible about the hazards that may be engendered when using a machine.

The installation activity requires special work conditions. Furthermore, the suitable precautions must be taken to prevent risks of injury to persons or damage.

It is recommended to always comply with the safety recommendations.

Cordon off the work site and prevent access to the area.

The work area must be kept tidy and must not be left unattended.

Do not wear clothes or accessories - such as ties or bracelets - that might get caught in moving parts.

Always wear the personal protective equipment recommended for the type of activity to be carried out.

Use work instruments in good conditions.

The required level of workplace lighting must be equal to at least 200 lux.

Use the transport and lifting equipment recommended in the instructions manual.

Use safety-compliant portable ladders of adequate size, fitted with anti-slip devices at the top and bottom, equipped with retainer hooks.

USER SAFETY



The person in charge of the automation is responsible for the operation of the system.

He or she is bound to read and comply with the instructions manual.

He/she must be in good psycho-physical conditions, aware of and responsible about the hazards that may be engendered when using a machine.

The required level of ambient lighting must be equal to at least 200 lux.

The person in charge of using the automation must prevent the control devices being used by anyone who has not been specifically authorised and trained to use them. He/she must not allow access to the control devices to persons under age or with reduced psycho-physical abilities, unless under supervision by an adult responsible for their safety.

Do not use the system in case of malfunctioning.

Under no circumstances is the user authorised to perform any work inside the housing of the automation or on any of its components.

The user is not permitted to perform any type of work on the motorisation or on components of the system.

If the system malfunctions, the user must not attempt any kind of repair or take any direct action. He/she must request assistance from the INSTALLER / MAINTENANCE TECHNICIAN.

The user must make sure that maintenance to the system is carried out according to the instructions provided in this manual.



The installer/maintenance technician must provide the user with all the information required to operate the system and for emergency situations.

The installer/maintenance technician must supply the system's Register to the owner.

1.2 MEANING OF THE SYMBOLS USED



Perform the operations and steps described in compliance with safety regulations and the instructions provided so as to prevent the risks indicated by the symbols in the following tables.

1 Symbols: notes and warnings on the instructions

CAUTION



It indicates the risk of personal injury or damage to parts. The described operation/step must be carried out in compliance with the instructions provided and with safety regulations.

WARNING ELECTRIC SHOCK HAZARD



Indicates risk of electrocution. The described operation/step must be carried out in compliance with the instructions provided and with safety regulations.

WARNING



Details and specifications to be followed with the utmost attention, in order to ensure correct operation of the system.

PAGE REFERENCE



It refers to the page indicated by the number for details or clarifications.

PICTURE REFERENCE



It refers to the picture indicated by the number.

TABLE REFERENCE



It refers to the table indicated by the number.



CAUTION

The batteries and electronic components must not be disposed of with household waste but delivered to authorised disposal and recycling centres.



2 Symbols: tools (type and size)



HEX WRENCH of the specified size (6, 8...)

6-8...



ALLEN KEY with ROUND HEAD of the specified size (6, 8...)

6-8...

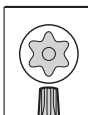

TORX WRENCH of the specified size (6, 8...)



CROSS-HEAD SCREWDRIVER of the specified size (6, 8...)

6-8...



METAL DRILL BITS of the specified size (6, 8...)

6-8...



MASONRY DRILL BITS of the specified size (6, 8...)

6-8...



LEVEL



COUNTERSINK with specified angle (45°...)

45° ...



ROUND SAW



PALLET FORKS



TOOL with TORQUE ADJUSTMENT

It indicates that a tool with torque adjustment is required where necessary for safety reasons.

FASTENING TORQUE VALUE

The torque wrench and the fastening torque in Nm is specified in the figures. E.g.: HEX WRENCH 6 set at 2.5 Nm

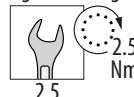

2.5

3 Symbols: safety signs and symbols (EN ISO 7010)



GENERIC HAZARD
It indicates the risk of personal injury or damage to parts.



ELECTROCUTION HAZARD
It indicates the risk of electrocution due to the presence of live parts.



RISK OF CRUSHING AND MUSCULO-SKELETAL DISORDERS
It indicates the risk of crushing and musculo-skeletal disorders due to lifting heavy parts.



BURNING OR SCALDING HAZARD
It indicates the risk of burning or scalding due to the presence of parts at high temperature.



CRUSHING HAZARD
It indicates the risk of crushing hands/feet due to the presence of heavy parts.



RISK OF CRUSHING HANDS
It indicates the risk of crushing hands due to the presence of moving parts.



CUTTING/AMPUTATION/PIERCING HAZARD
It indicates the risk of cutting due to the presence of sharp parts or using pointed tools (drill).



SHEARING HAZARD
It indicates the risk of shearing due to moving parts.



RISK OF IMPACT/CRUSHING
It indicates the risk of impact or crushing due to moving parts.



FALLING OBJECTS HAZARD
It indicates the risk of impact due to falling objects.



SPENT BATTERIES HAZARD
It indicates a risk for the environment and health arising from spent batteries due to possible leakage of the liquid content.



COLLISION WITH FORKLIFT TRUCKS HAZARD
It indicates a risk of collision/impact with forklift trucks.

6 Symbols: markings on product



Obligation to read the instructions

4 Symbols: Personal Protective Equipment

Personal protective equipment to be worn for protection from any risks (e.g. crushing, cutting, shearing, etc.):



Obligation to wear head protection helmet.



Obligation to wear safety footwear.



Obligation to wear mask/goggles to protect the eyes from the risk of fragments due to the use of drill or welder.



Obligation to wear work gloves.



Obligation to wear ear protectors.



Obligation to wear overalls. Do not wear clothes or accessories - such as ties or bracelets - that might get caught in moving parts.

5 Symbols: markings on packaging

Important warnings for the safety of people and integrity of the load:



Handle with care. Presence of fragile parts.



Store away from water and humidity.



PROHIBITION to stack items.



Maximum number of stackable items, e.g.: 2.



Wear work gloves.



Wear safety footwear.



Use pallet trucks.



Use forklift trucks.



20 kg is the MAX weight that 1 person can lift.

Kg _____ WEIGHT of the load.

2. AUTOMATION AIRSLIDE

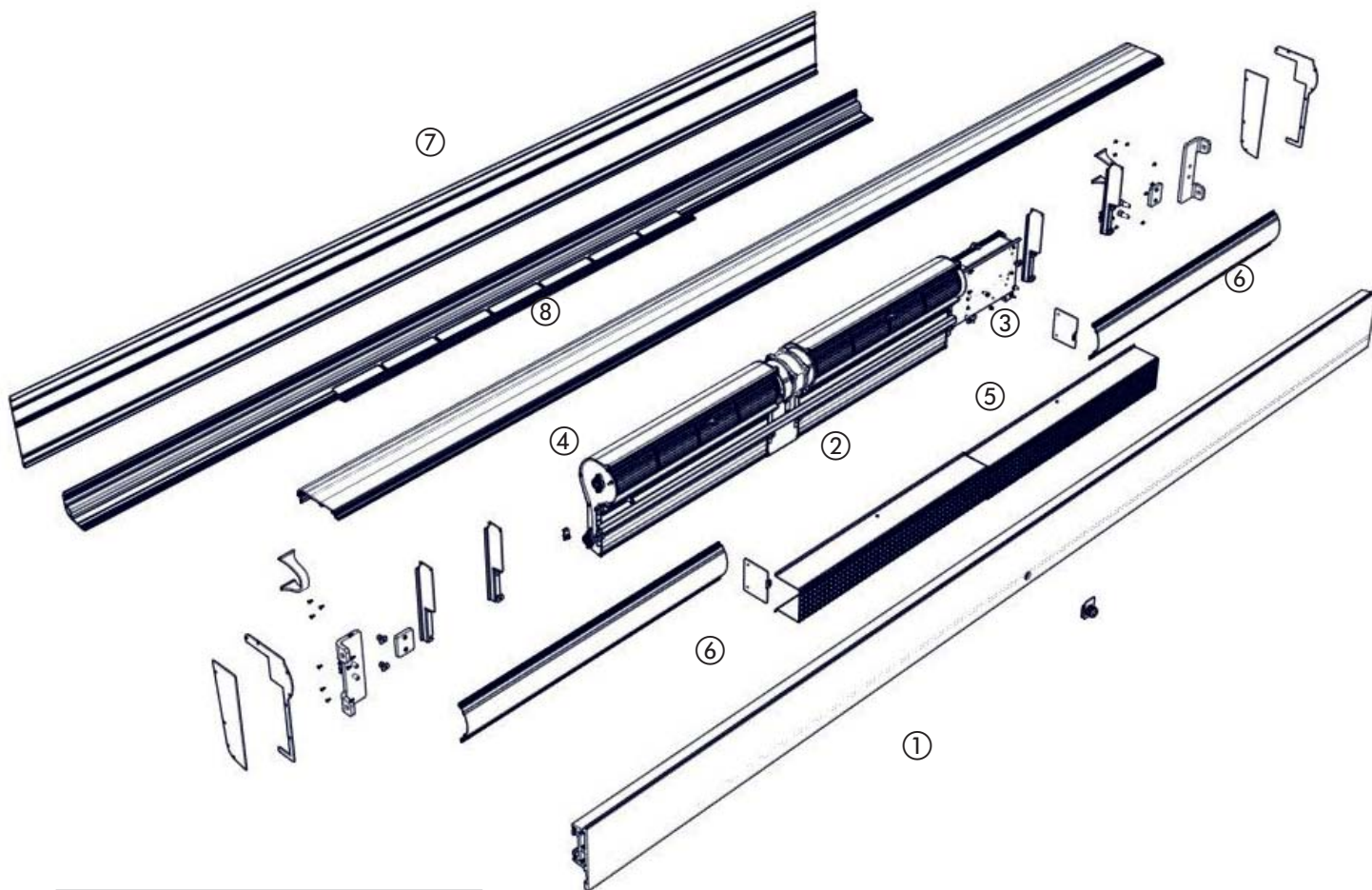

- | | |
|---|---------------------|
| 1 | Main profile |
| 2 | Electric fan unit |
| 3 | Plate with board |
| 4 | Upper cover |
| 5 | Intake grilles |
| 6 | Side covers |
| 7 | Casing |
| 8 | Casing with grilles |

2.1 INTENDED USE

The AIRSLIDE systems with integrated air blade at the entry ensure a greater level of insulation between the indoor and outdoor environment, protecting the entrance area from winter cold and summer heat without dispersion, also protecting the rooms from dust, pollution and insects from the outside area. .

The AIRSLIDE series automations are designed to automate entry doors that are used exclusively for pedestrian traffic.

They are compliant with standard EN 16005:2012.

They are suitable for installation indoors, for applications which meet the specifications given in [7](#).



No other use outside the ones set out above is allowed by the manufacturer.

FAAC declines all liability deriving from misuse or uses other than that for which the automation s intended.

LIMITATIONS FOR USE

Do not use the automation in the presence of the following conditions:

- exposure to direct water jets of any type or extent
- outside the technical limitations set out. Specifically, it is forbidden to connect to sources of energy other than those set out.

2.2 UNAUTHORISED USE

It is forbidden to:

- use the automation for uses other than THE INTENDED USE;
- use the automation for installing smoke and/or fire protection doors (fire doors);
- use the automation with mobile and fixed guards tampered with or removed;
- use the automation in environments in which there is a risk of explosion and/or fire: the presence of flammable gases or fumes is a serious safety hazard (the product is not 94/9/EC ATEX certified);
- integrate other systems and/or commercial equipment not intended;
- use other systems and/or commercial equipment for uses not authorised by the respective manufacturers;
- use commercial devices for purposes other than those set out by the respective manufacturers.

2.3 TECHNICAL SPECIFICATIONS AIRSLIDE

7 Technical specifications

MODEL	AIRSLIDE
MAX installation height (m)	2.5
MAX recommended opening width (m)	2.2
Power supply voltage	220-240V~ 50-60Hz
MAX absorbed power [W]	160 (single motor) - 330 (double motor)
Electric motor	Asynchronous single phase motor
Motor rotation speed (rpm)	2850
Beam dimension (D x H) (mm)	182.1 x 252.5 (Including Grille)
Fan diameter (mm)	80
Fan length (mm)	360 - 500
Speed of air output from the grilles from 0 to 2.5m in height (m/s)	15.3 - 4.2
Air flow rate (m3/h)	1250
Noise level (dB) at 5m	49.5 - 57.5
Operating ambient temperature [°C]	-20° / +55°
Automation protection rating	IP23
Use frequency	100%

AIRSLIDE SERIAL NUMBER AND RATING LABEL



AIRSLIDE COMPONENTS

Support profile



Main profile AIRSLIDE for assembly of components and plate.

Side fixing plates (Optional)

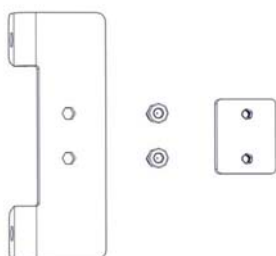

Support profile side fixing plates

FRONT CASING CLOSING PROFILE

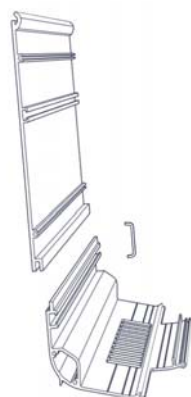

Aluminium profile for front head section closure.

Plates with screws



plates with screws for installation of components.

Master electric fan unit and E1AS board plate

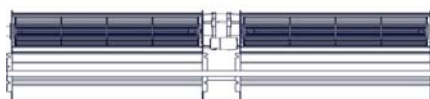

Master electric fan unit and E1AS board plate.

Additional fan module

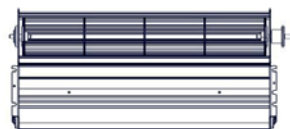

Additional electric fan module to be connected to the master electric fan module

Slave electric fan unit

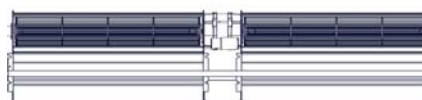

Slave electric fan module to be connected

Side profiles

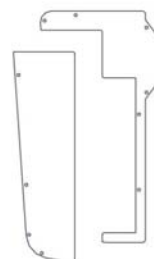

Side profiles AIRSLIDE.

Intake grilles



Grilles AIRSLIDE

Side covers and side panels

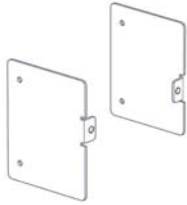

Side cover AIRSLIDE and side panels

Upper cover and brackets

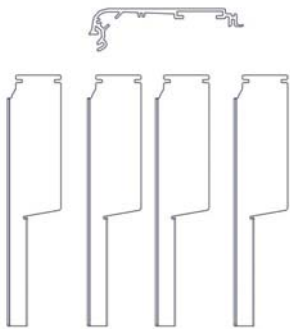

Upper cover and fastening brackets

2.4 TYPES OF SYSTEM SUPPLIED

The AIRSLIDE series systems may be supplied as follows:

- Air curtain in kit form for automatic entry: AIRSLIDE KIT
- Assembled air curtain for automatic entry: AIRSLIDE PA
- Automatic entry with integrated air curtain : AIRSLIDE CS

INSTALLATION ACCORDING TO THE TYPE OF SYSTEM SUPPLIED



During installation, it is recommended to comply with the order of the sections set out based on the type of purchased supply.

AIRSLIDE KIT



- A. Pack containing AIRSLIDE components to be assembled on the FAAC support profile.
- B. Pack with FAAC profiles purchased in 6.10 m long bars.

AIRSLIDE PA



- C. Automation assembled on FAAC* head section..
- F. AIRSLIDE assembled.*

AIRSLIDE CS

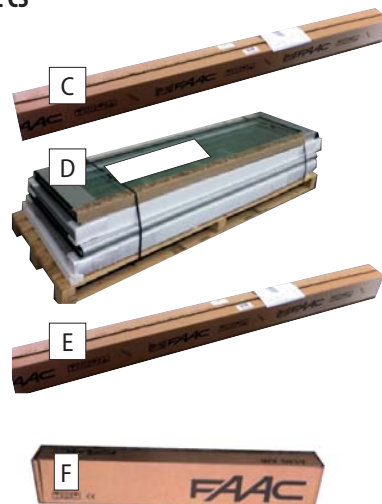

- C. Automation assembled on FAAC* head section.
- D. FAAC leaves (with TK20 or TK50 profiles)
- E. Package with TK20 or TK50 profiles for installing the FAAC door wall frame.
- F. AIRSLIDE assembled.*

* Supplied with the required measurement and with pre-assembled automation components.

3. INSPECTION AND PREPARATION

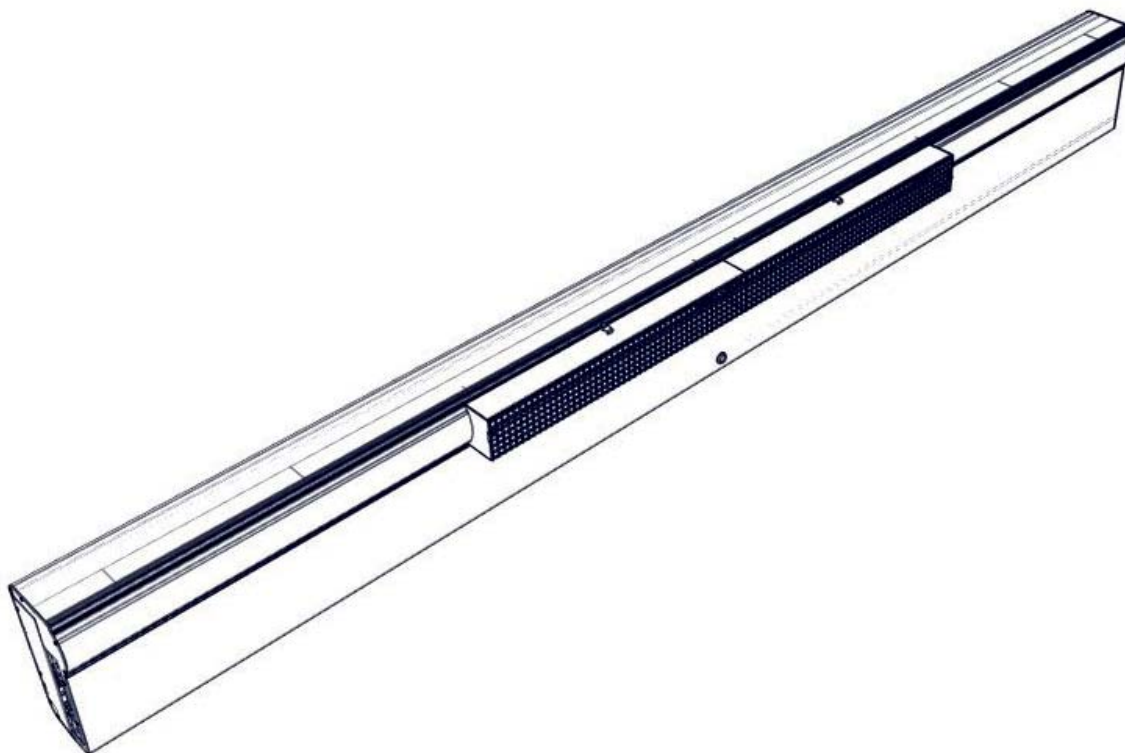

3.1 PRELIMINARY INSPECTION



Prior to installation, check soundness of the load bearing masonry structure and door. Perform any required work to assure:

- solidity, stability and absence of any risk of detachment or collapse of the masonry structure, fixed door frame and automation
- level flooring, without any friction/hindrance to smooth leaf sliding
- absence of sharp edges (cutting hazard)
- absence of protruding parts (hooking/entrapment hazard)

3.2 ARRANGEMENT OF ELECTRICAL CABLES



Before performing any operation on the system, disconnect the power supply.

The electrical system must be compliant with the regulations in force in the Country of installation (EN 60335-1...)

The power mains of the automation must be fitted with a multi-pole power switch with a switch-contact gap of at least 3 mm. It is advisable to use a 6A circuit breaker with a multi-pole power switch.

Ensure there is a residual current device with a 0.03 A threshold upstream of the system.



Ensure the earthing system is constructed in a workmanlike manner and connect the structure's metal parts to it.

If it is necessary to control board E1AS remotely, provide additional cables to maintain a continuous earth .

Lay the electrical cables for connecting the accessories and the electrical power supply  4.

Protect cables by means of suitable ducting.



Place control accessories within the automation's visual range. These devices must always be accessible, even with the door open.

Comply with the following heights from the ground:

- control accessories = minimum 150 cm
- emergency buttons = max 120 cm

4. TRANSPORT AND RECEIPT OF THE GOODS

4.1 HANDLE PACKAGES



Always comply with instructions on the package.



The NET WEIGHT is indicated on the package.

PALLETISED SUPPLY

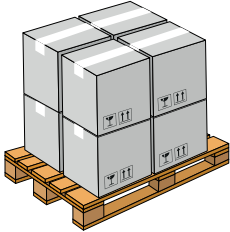

RISKS



PERSONAL PROTECTIVE EQUIPMENT



REQUIRED TOOLS



SINGLE PACKAGE

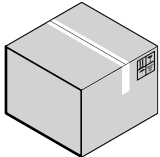

RISKS



PERSONAL PROTECTIVE EQUIPMENT



REQUIRED TOOLS



For manual lifting, there should be 1 person for every 20 kg to be lifted.

4.2 UNPACK AND HANDLE

RISKS



PERSONAL PROTECTIVE EQUIPMENT



REQUIRED TOOLS



For manual lifting, arrange for an adequate number of people for the weight of the leaf: 1 person for every 20 kg to be lifted.

1. Open and remove all packaging elements.
2. Make sure that all components requested are present and undamaged.



If the goods supplied are non-compliant, proceed as indicated in the General Conditions of Sale listed in the sales catalogue and which can be consulted on the website www.faacgroup.com.

The unpacked goods must be handled manually.



Should transport be required, the products must be suitably packaged.

Discard the packaging after use in the appropriate containers in compliance with waste disposal regulations.

The packaging materials (plastic, polystyrene, etc.) must not be left within reach of children as they are potential sources of danger.

5. CUTTING THE PROFILES

i If the AIRSLIDE KIT has been supplied, the profiles must be cut to the size indicated. This operation is performed in the shop. After cutting, assemble the components to the support profile.

Handling instructions:  20.

RISKS



PERSONAL PROTECTIVE EQUIPMENT



REQUIRED TOOLS



Use a circular or linear saw cutting machine with blade suitable for cutting metals.

It is forbidden to use a hand saw.

Only use equipment in good conditions and fitted with all the required safety devices.

Always comply with the instructions provided by the equipment's manufacturer.

Cutting operations may only be performed by personnel authorised to use the equipment.



Make the cuts to the specified measurements.

6. ASSEMBLING THE HEAD SECTION

i If the AIRSLIDE KIT has been supplied, the components must be installed on the support profile. This operation is performed in the shop. The assembled head section is then moved to the installation site.

Handling instructions  21.

RISKS



PERSONAL PROTECTIVE EQUIPMENT

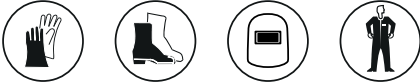

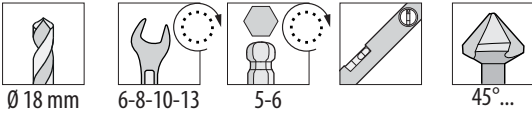

REQUIRED TOOLS



! A torque wrench must be used to achieve the specified fastening torques (Nm).

max 20kg For manual lifting, arrange for an adequate number of people for the weight of the leaf: 1 person for every 20 kg to be lifted.

6.1 ELECTRIC FAN MODULE AND PLATE WITH CASE FOR E1AS BOARD

The electric fan module is supplied pre-assembled. Also supplied is a plate with case attached containing the E1AS electronic board and wiring connectors  1. A protective sheathing for the cables is provided, and must be applied to the edges of the modules  1-①. The modules must be positioned so that they correspond with the air outlet slots in the casing  1-②.

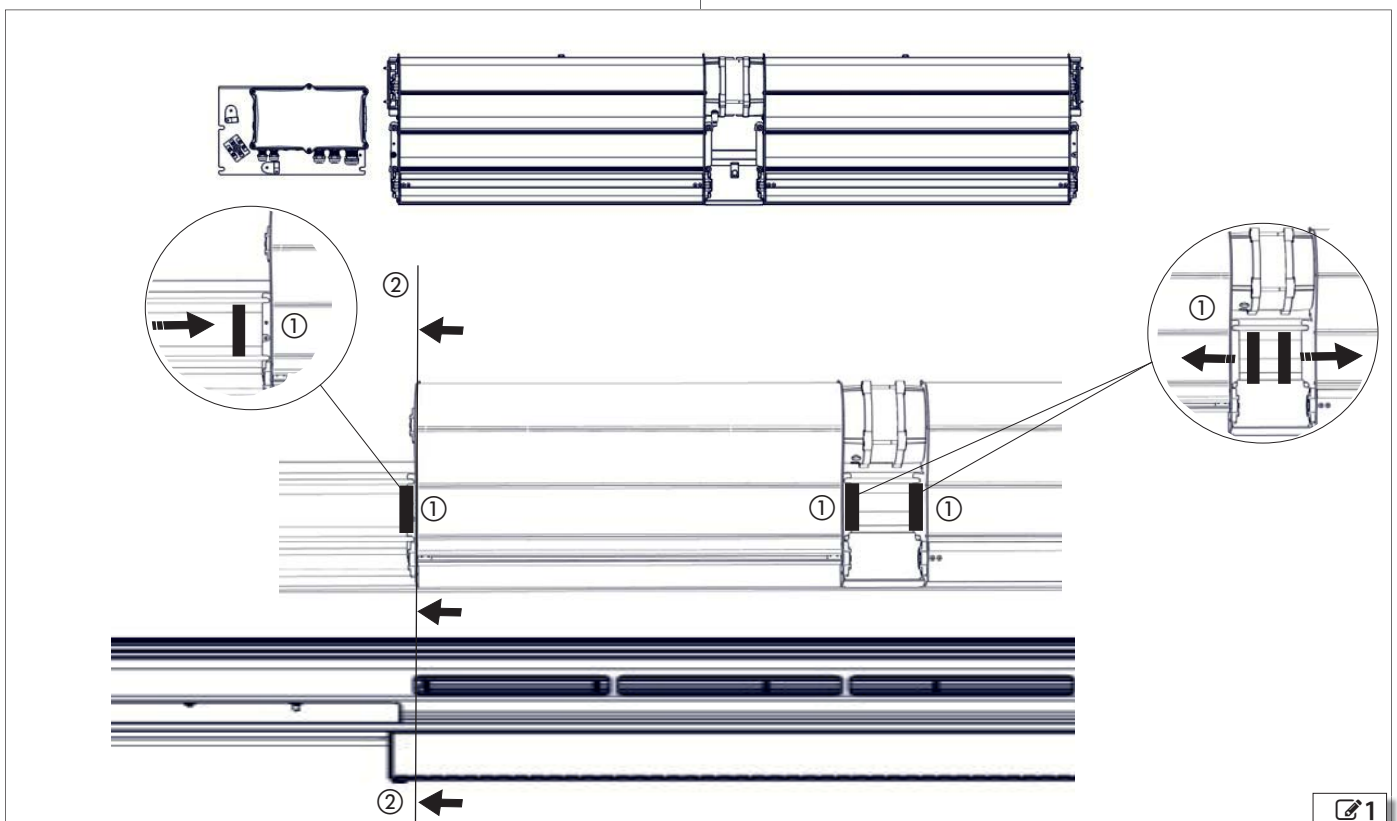

 1

Make a hole in the main profile for fitting the lock  2.

 If holes are drilled in the head section to allow passage of the power cables, fit a cable guard to protect it from any sharp borders and burs.

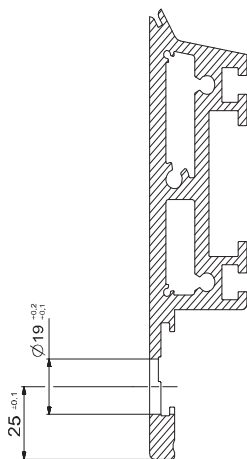
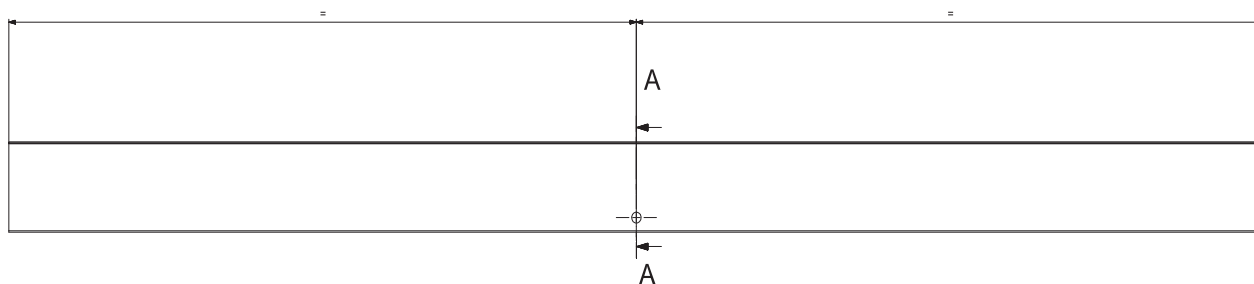

SECTION A-A

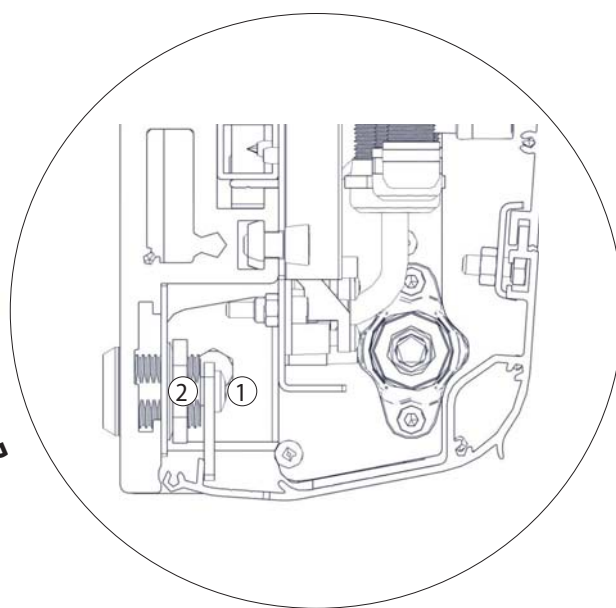
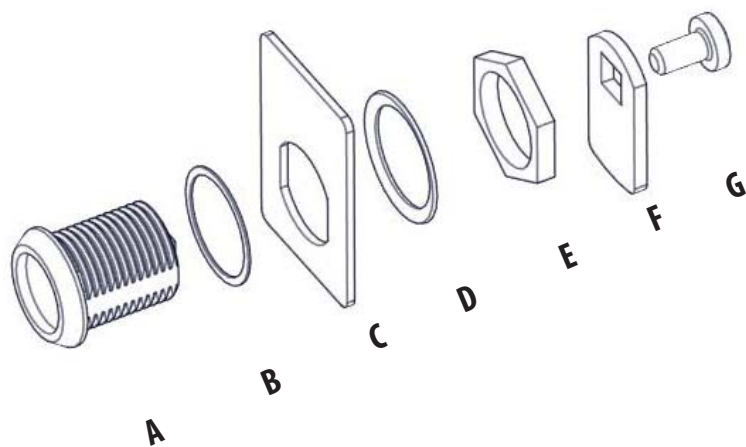
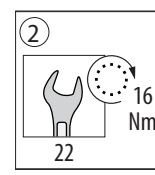
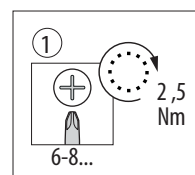
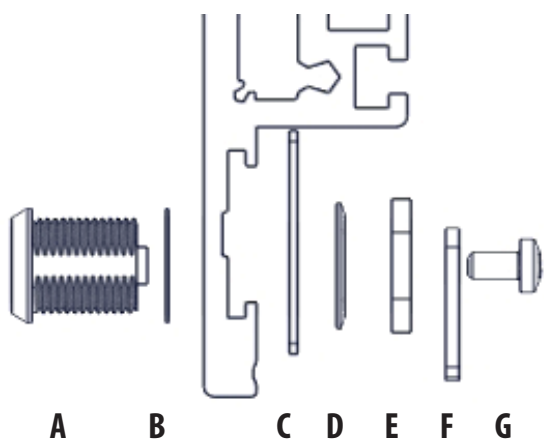

The unit is fixed to profile AIRSLIDE using fastener plates with M6 screws inserted in the profile. Fasten the electronic module plate using three fastener plates and M6 screws and fasten each fan module using two fastener plates and M6 screws on each side 3-①. Insert the protective cable sheath at the sides of the modules 1-①



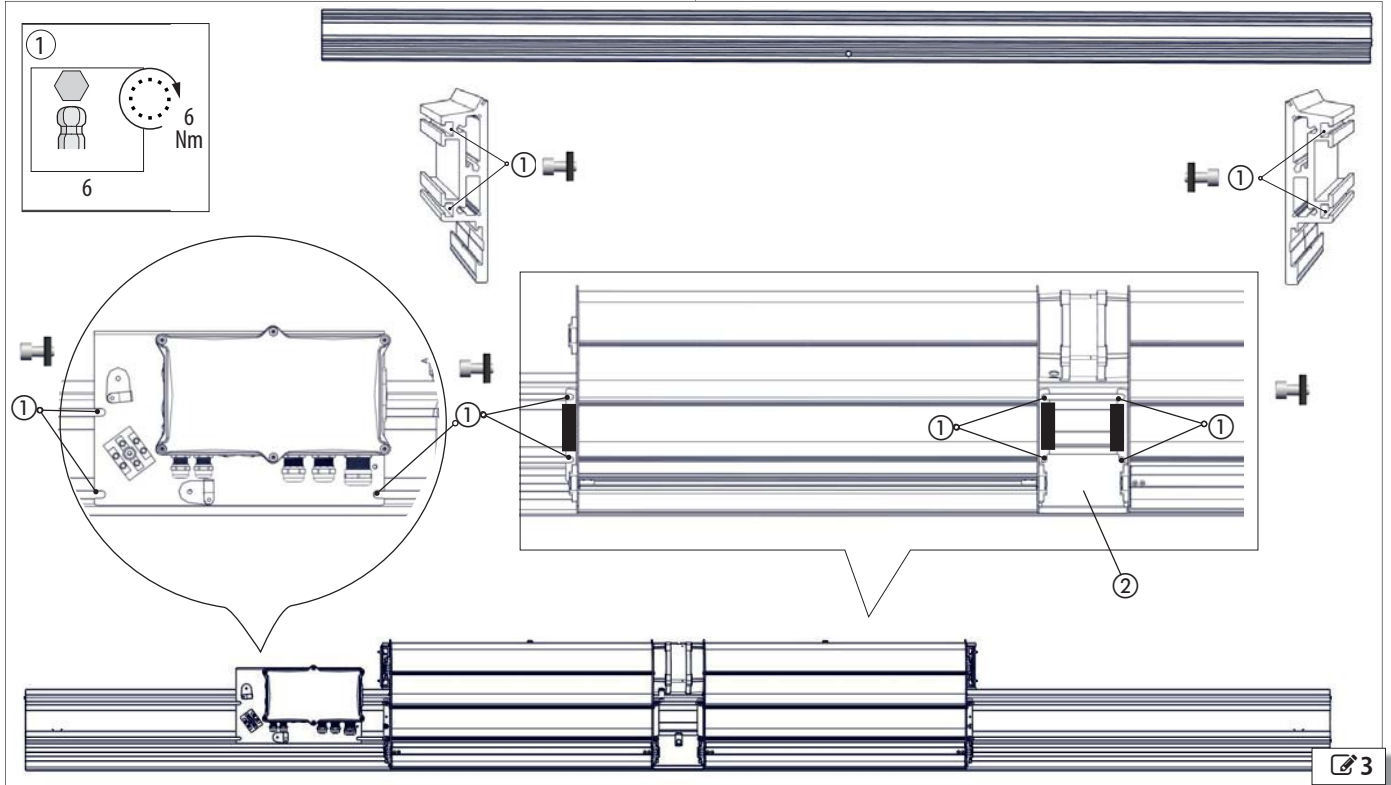

Do not install devices which could cause condensation or other liquid above the electronics module plate in order to prevent liquid dripping onto the E1AS electronic board case.



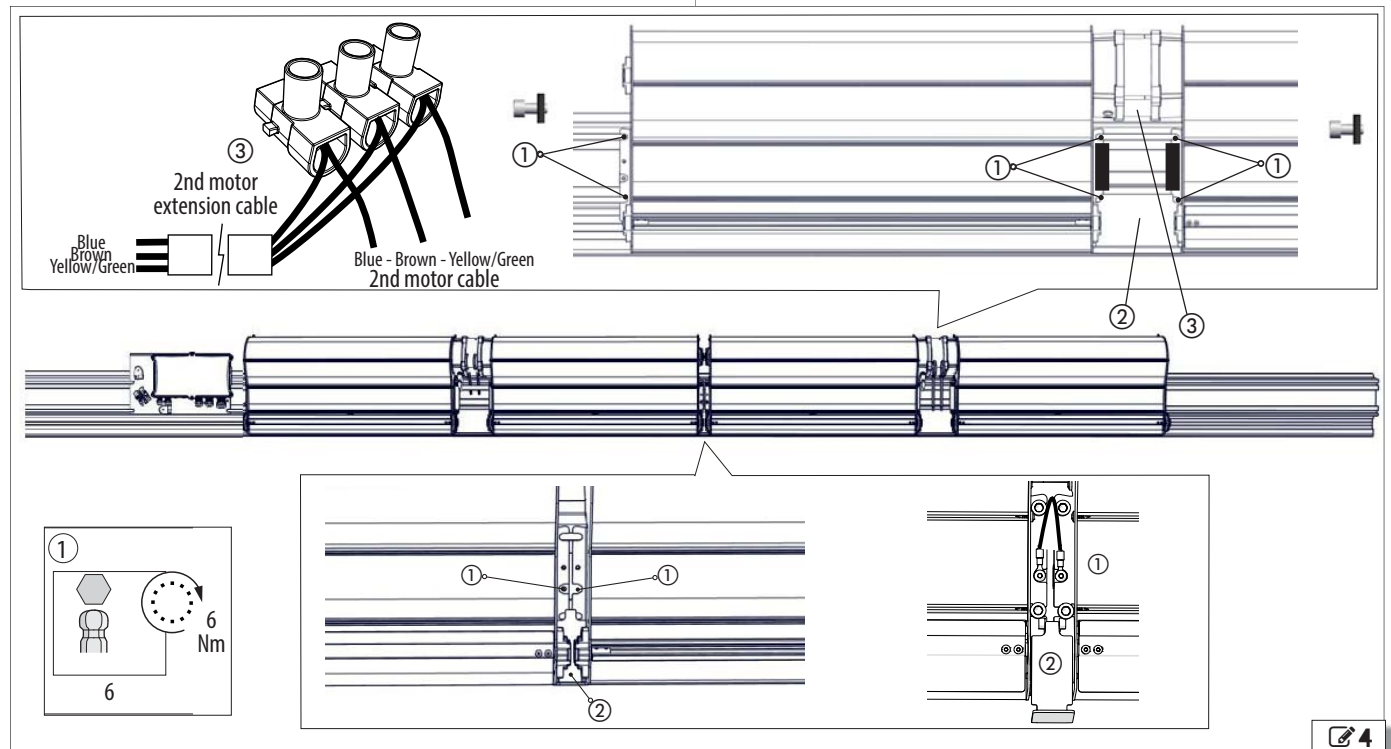

In the version with Slave electric fan unit alongside the main electric fan unit, connect the second motor with a joint to a cable that is to be connected to the E1AS board. Connect the 2 units to a ground cable 4-①. Use the lower fastening screws for the main electric fan unit and a screw from the Slave electric fan unit to fasten the plug 4-②. Insert the protective cable sheath at the sides of the modules 1-①



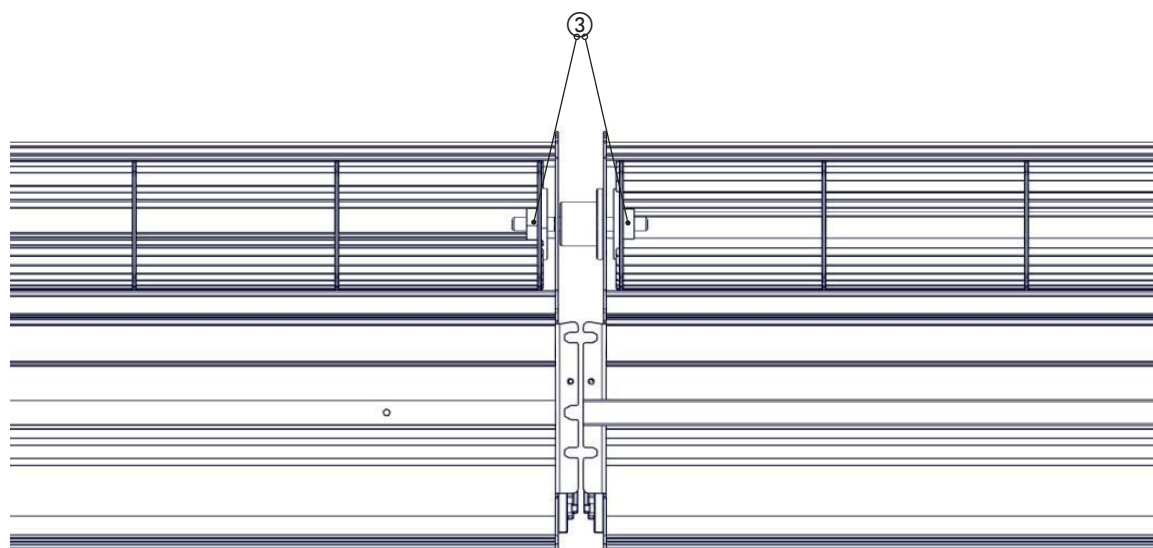
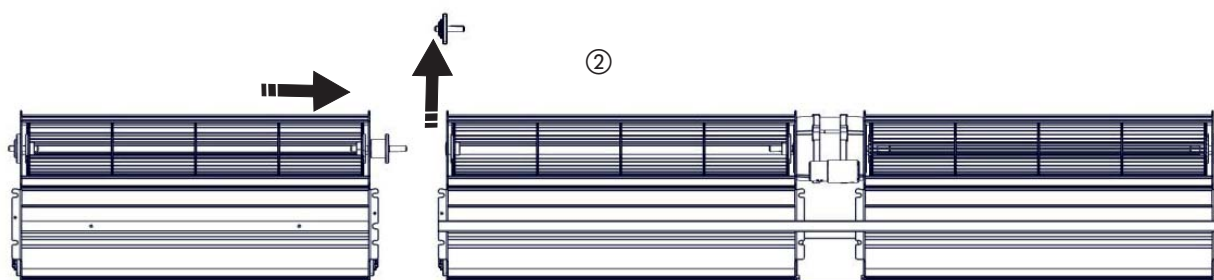
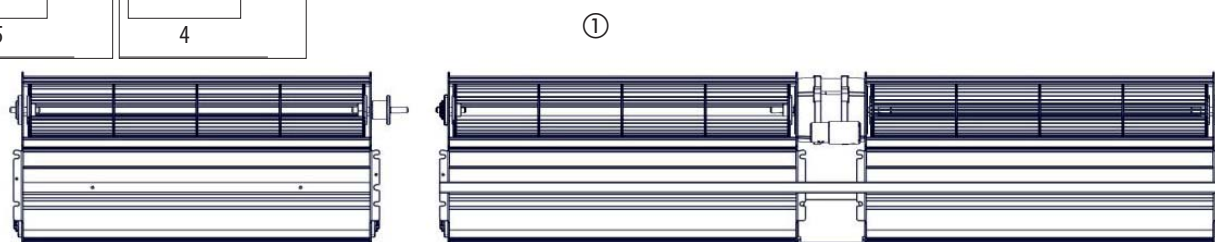
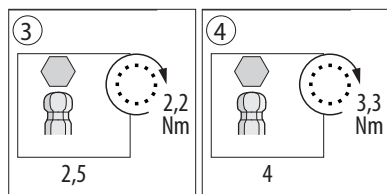

Assembly of the additional module

To insert the additional module, remove the flange from the main electric fan  5-①, loosening the hex socket screw on the main fan, and insert the pin of the additional fan  5-②. Check that the hex socket screws of the main and additional fan are lined up, then tighten screw  5-③

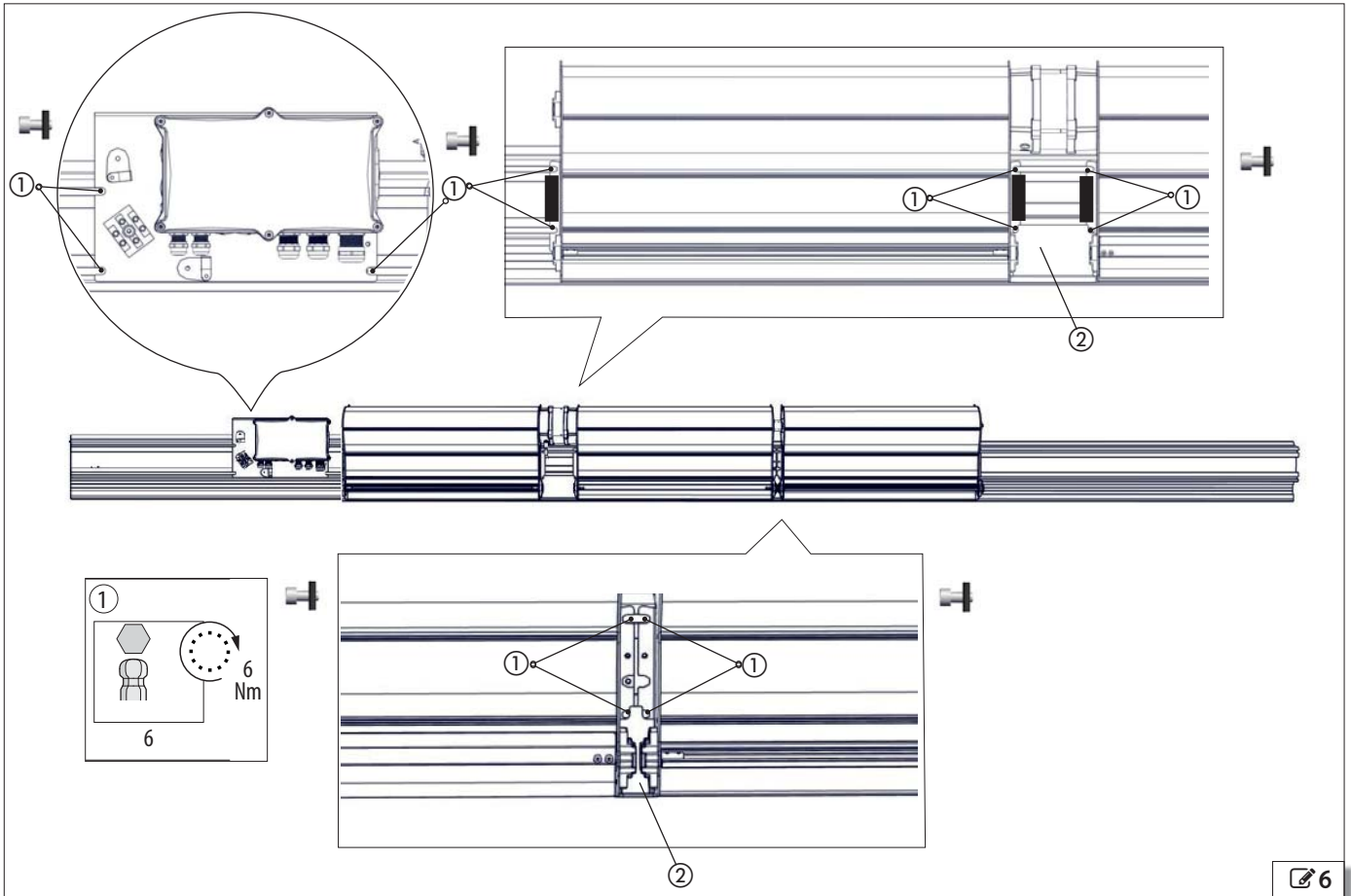

Fasten the electronic module plate using three fastener plates and M6 hex socket screws, and fasten each fan module using two fastener plates with M6 hex socket screws per side  6-①. Use the plugs provided to close the spaces between the fans  6-②



Insert the electric fan unit in the upper cover profile as shown in  7-① .

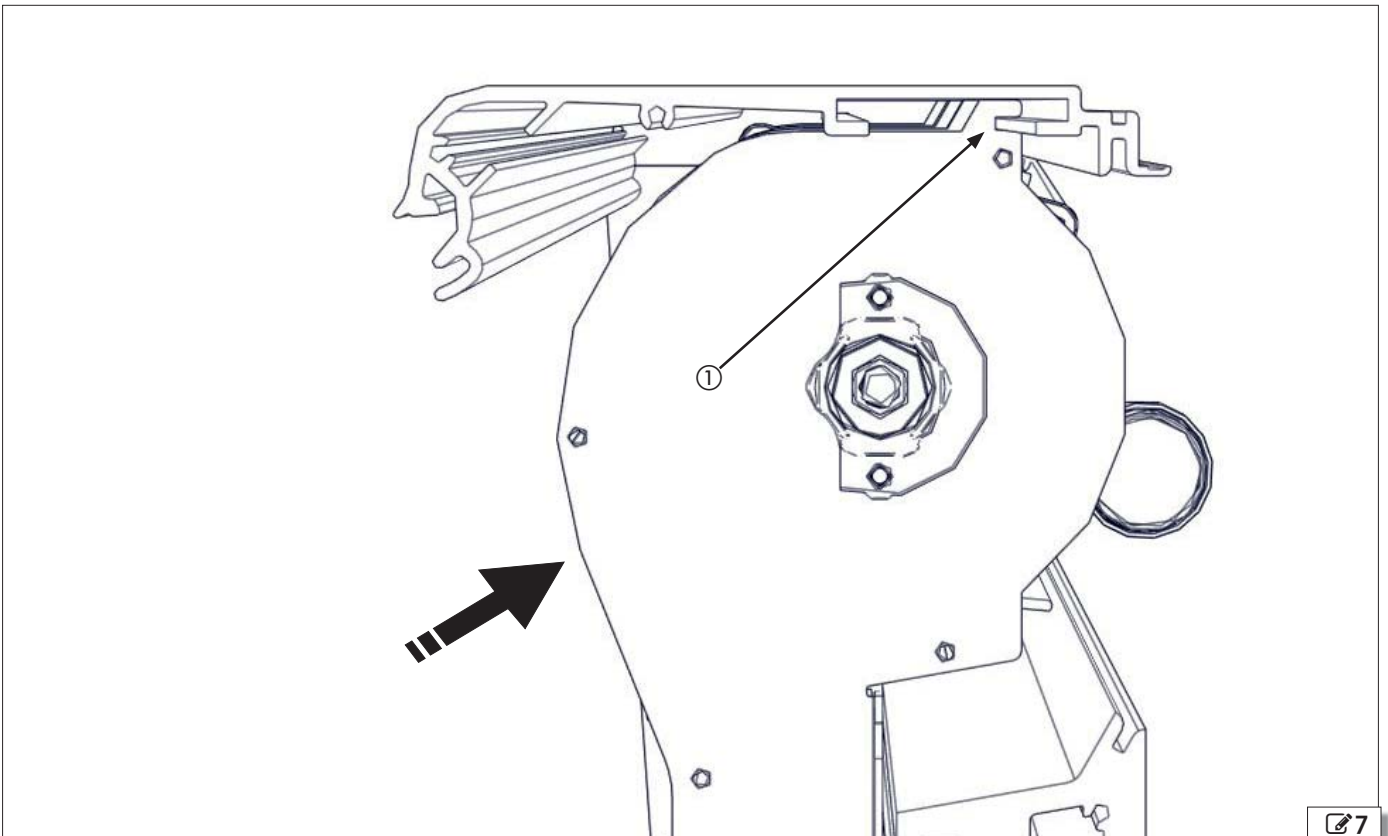



Use four brackets to fix the upper cover; these should be distributed 2 at each end of the head section AIRSLIDE.

Rotate the brackets to insert them in the upper cover.

i Check that the brackets are vertical with respect to the profile.

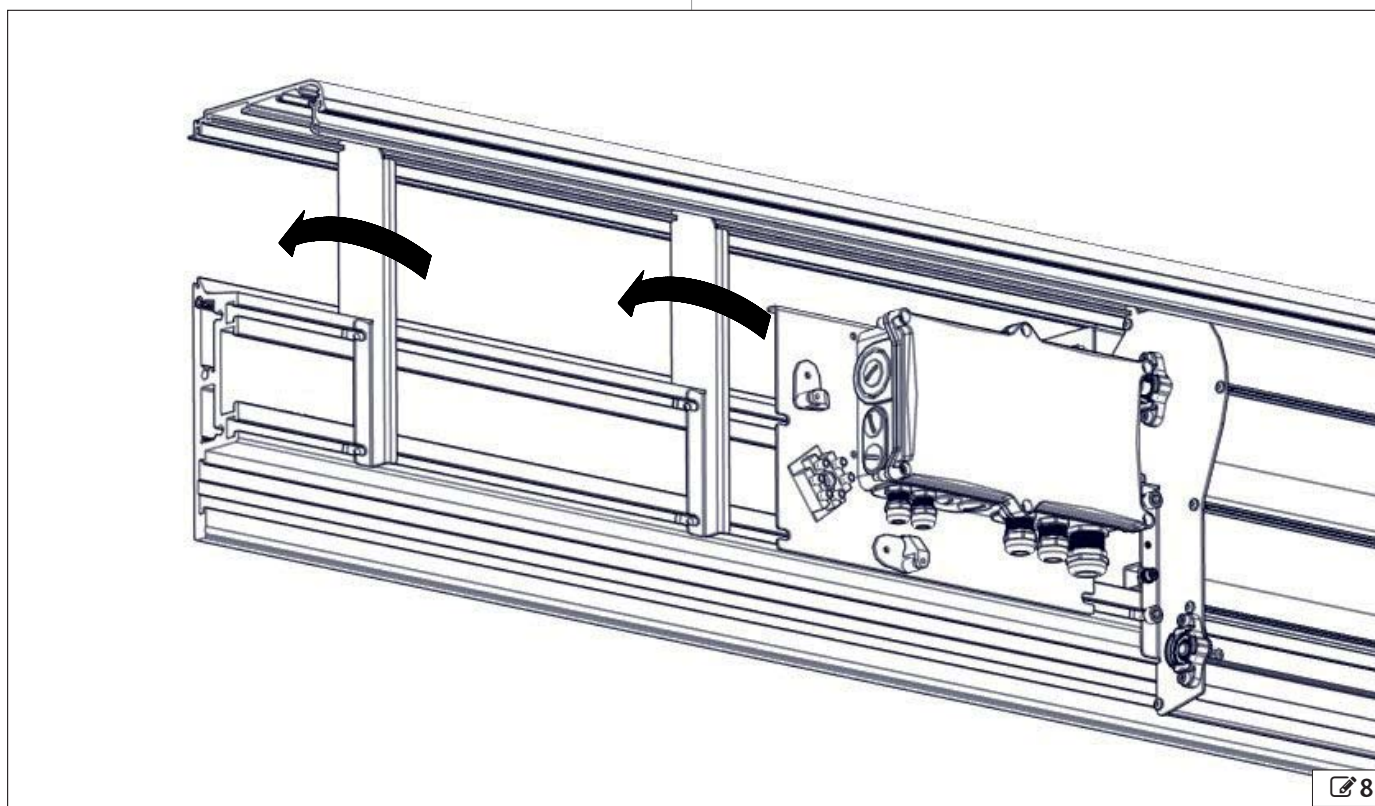
Fasten the brackets to the profile using the plates with M6 hex socket screws provided  8-①.



Tighten the hex head screws to the torques specified in  9-①.

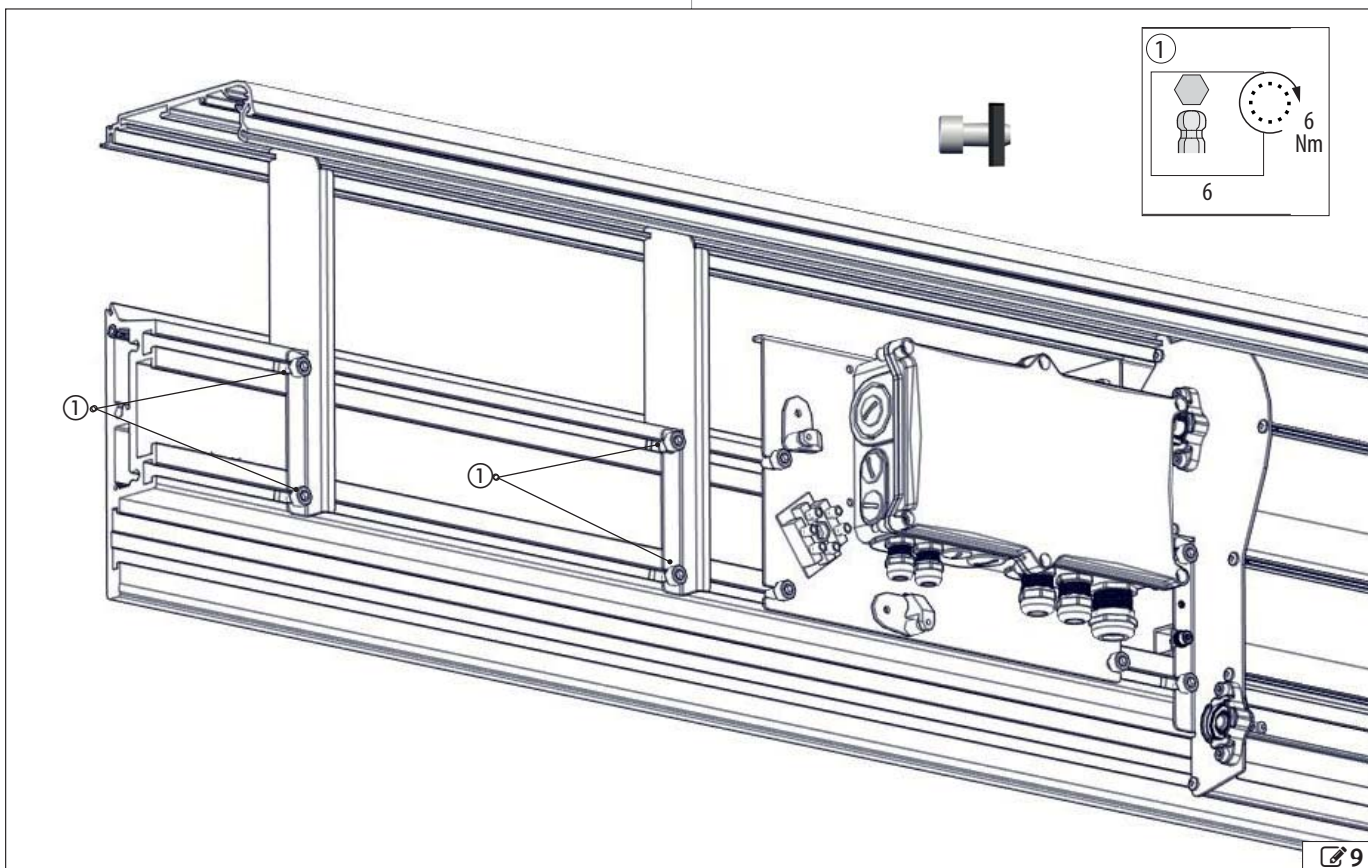

Insert the grilles to the side.  10

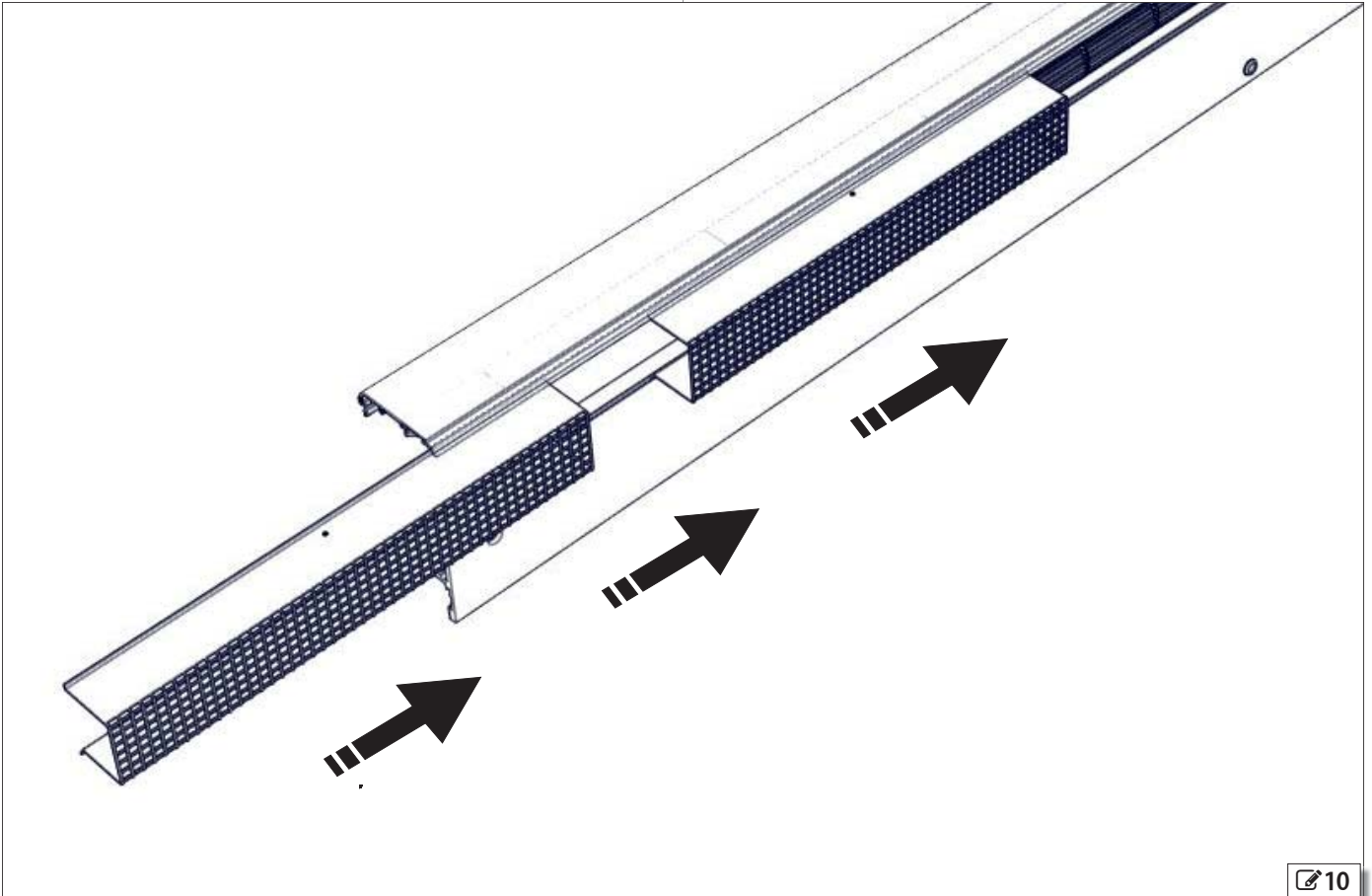

Assemble the side covers with the panels using the screws supplied  11-①.

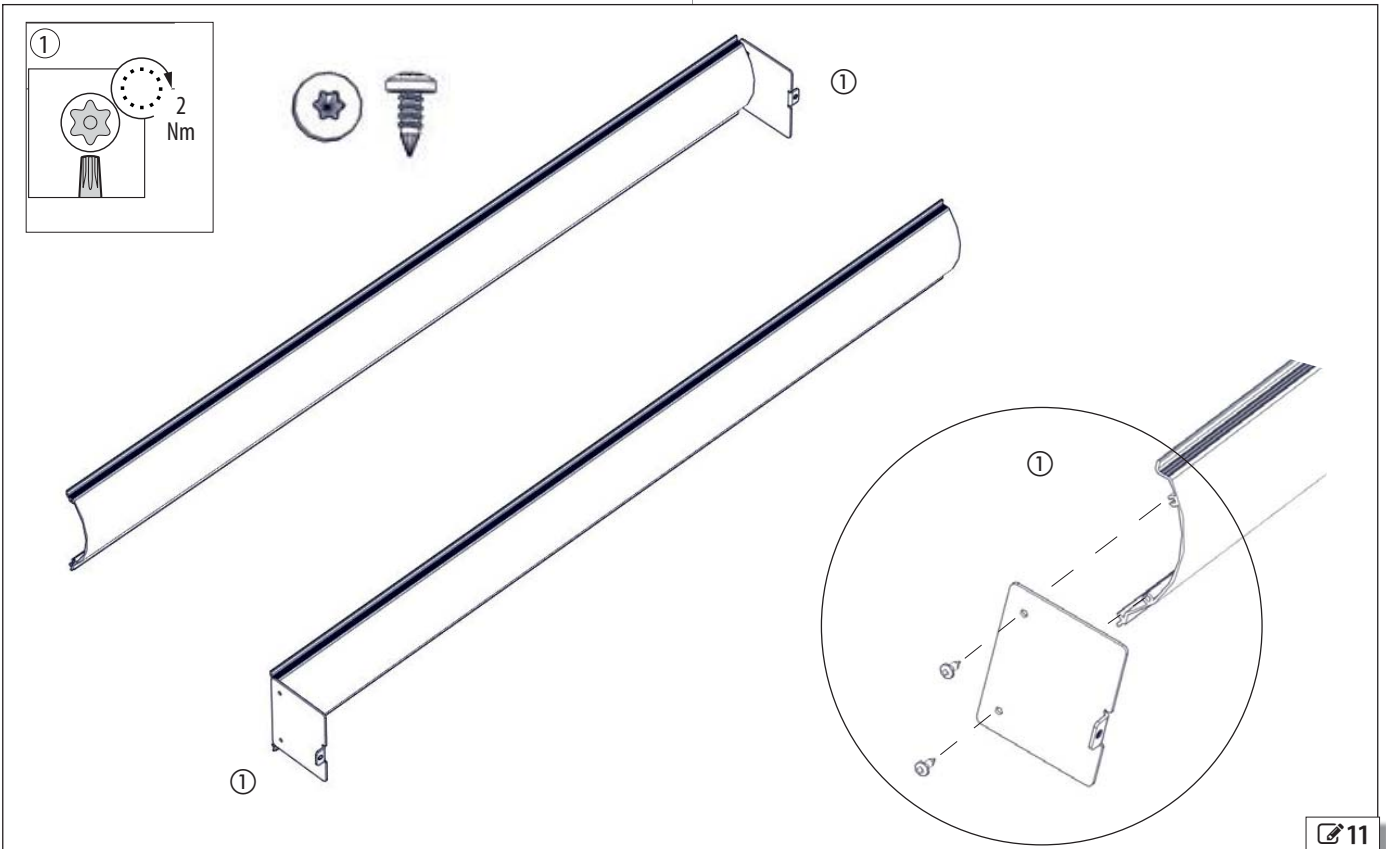

Then insert the assembled side covers  12.

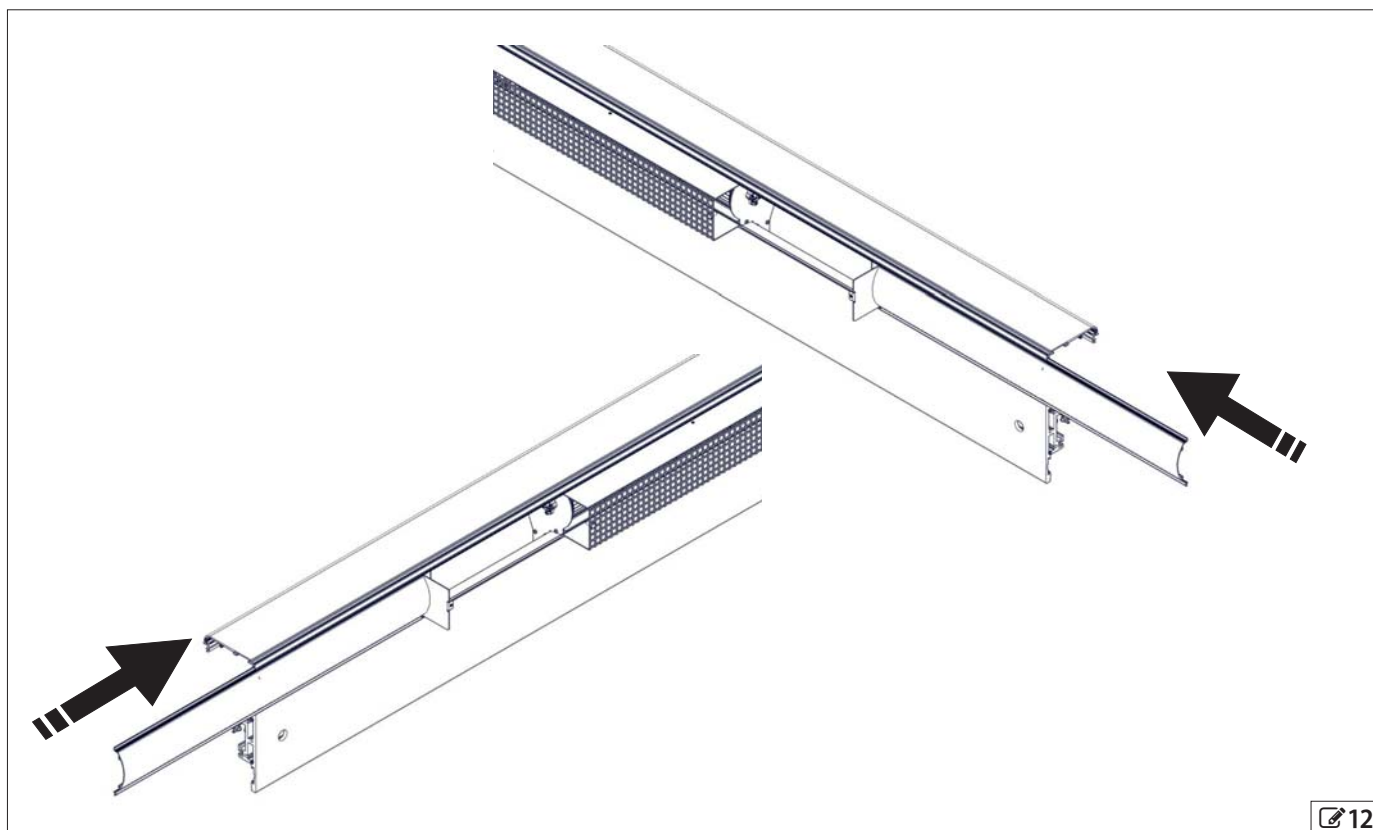

 12

Fasten the grilles to the top profile with the screws and clips supplied . Use a grille clip .  13-①

Fasten the side cover panels to the grille using the screws and washers supplied  13-②.

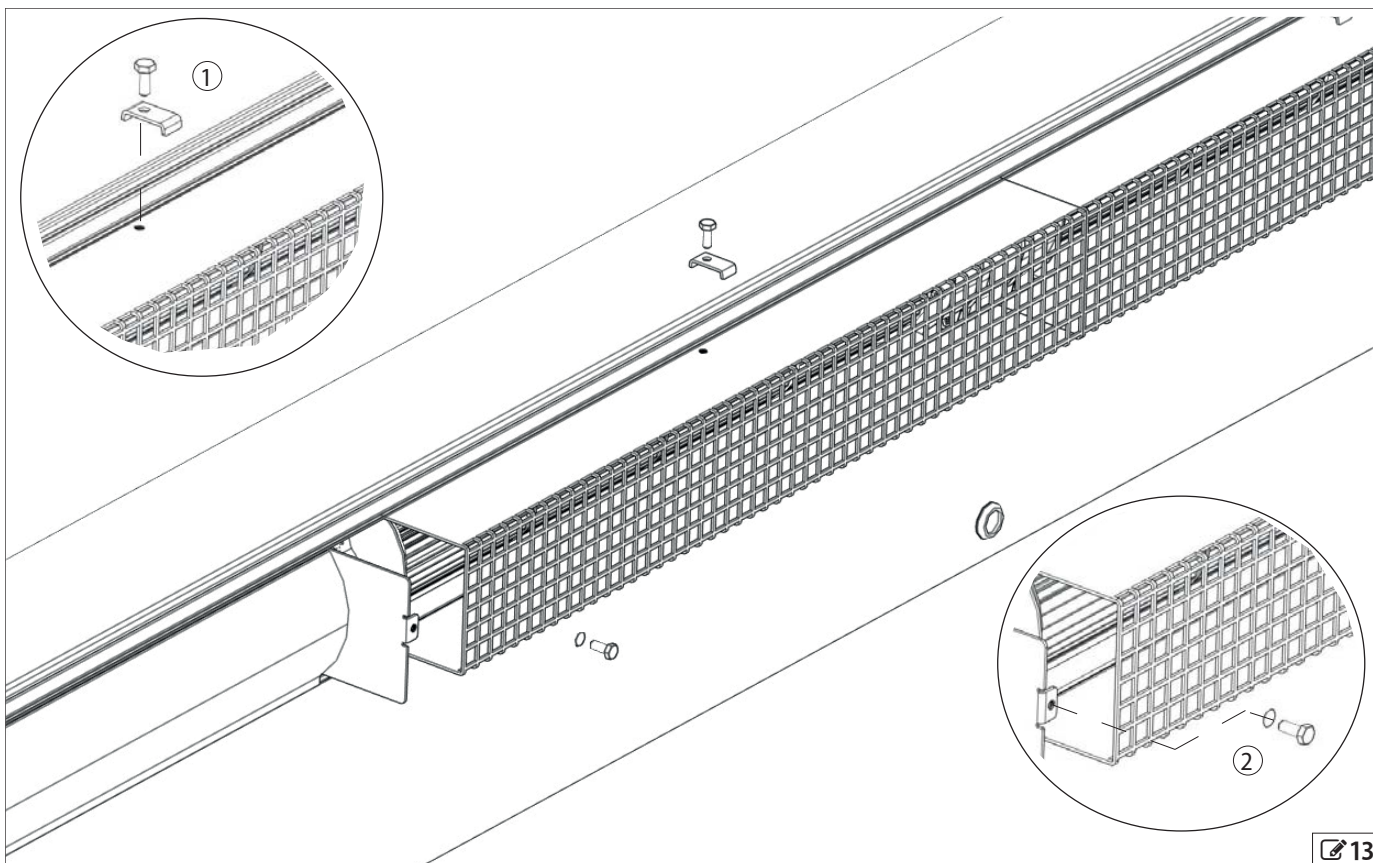

 13

Tighten the screws to the torques specified in 14-① ②.

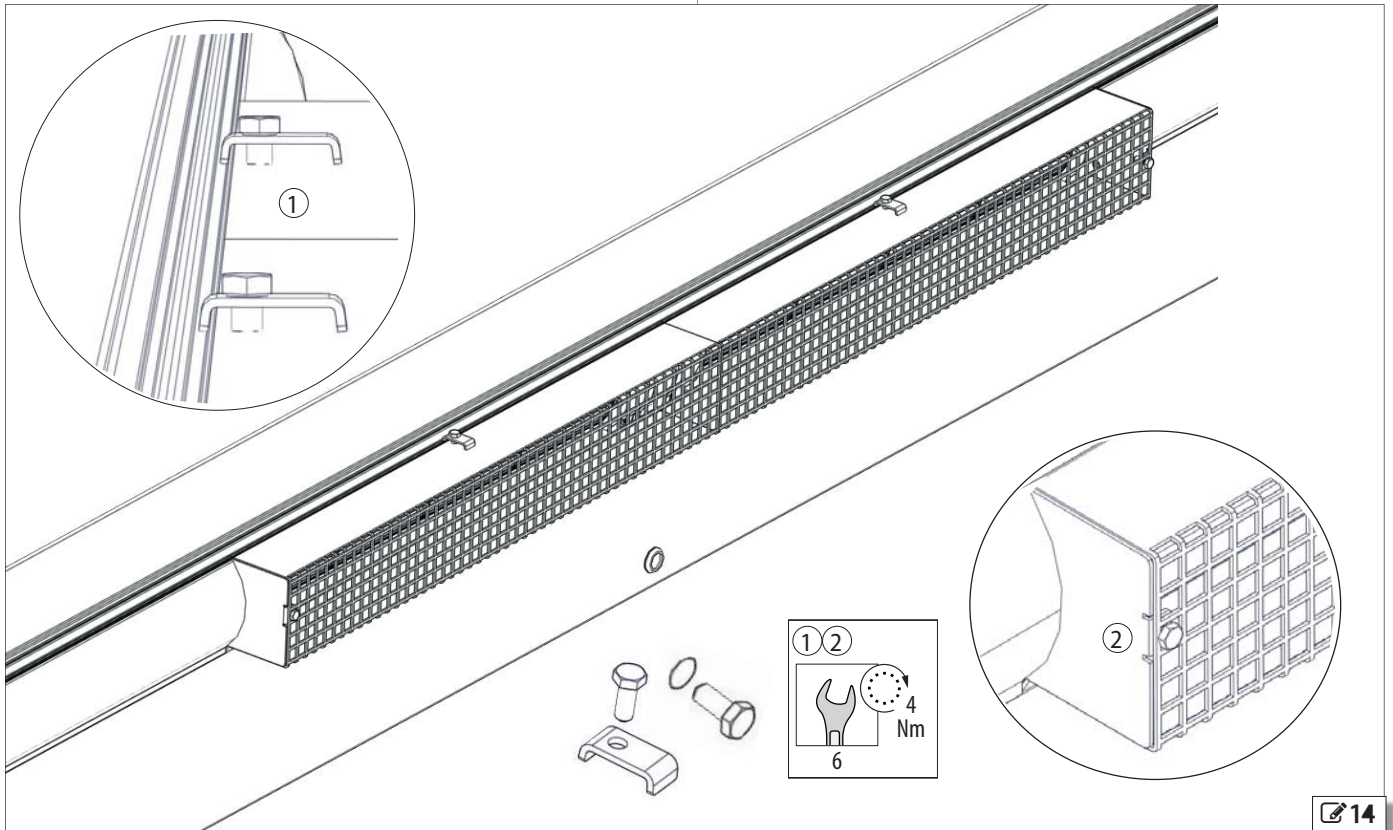

14

Insert the parachute cables 15-②.
 Insert the side panels after countersinking the holes.
 A 90 degree countersink must be used for the left and right sides.
 Fasten the plates with the screws provided, tightening to the torques specified in 15-①.

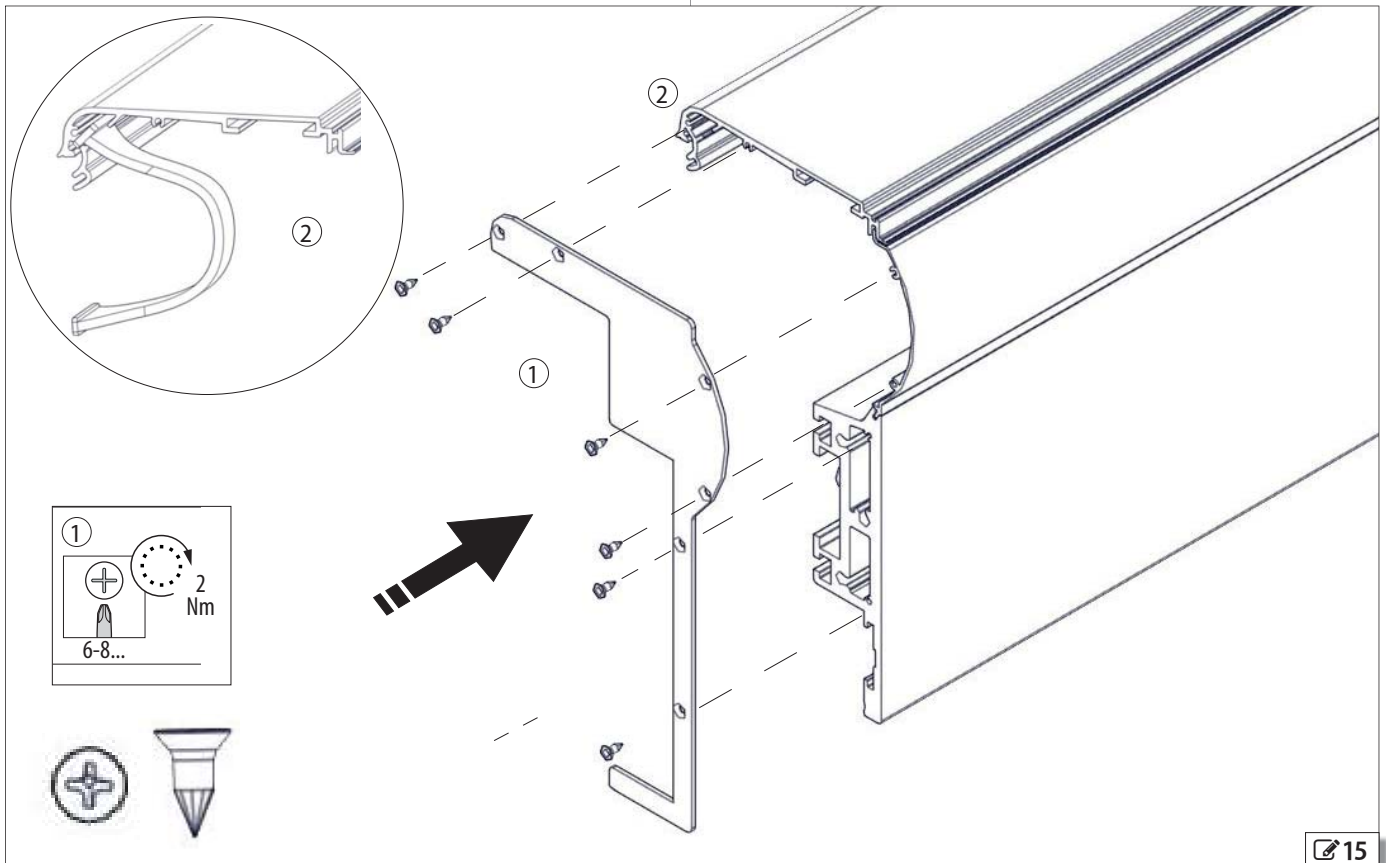



15

AIRSLIDE casing assembly.

Assemble the casing and fasten it with brackets and screws.

Insert the parachute cables  16-①.

Insert the panels at the sides after countersinking the holes.

A 90 degree countersink must be used for the left and right sides and fastened with the screws provided  16 and  17 .

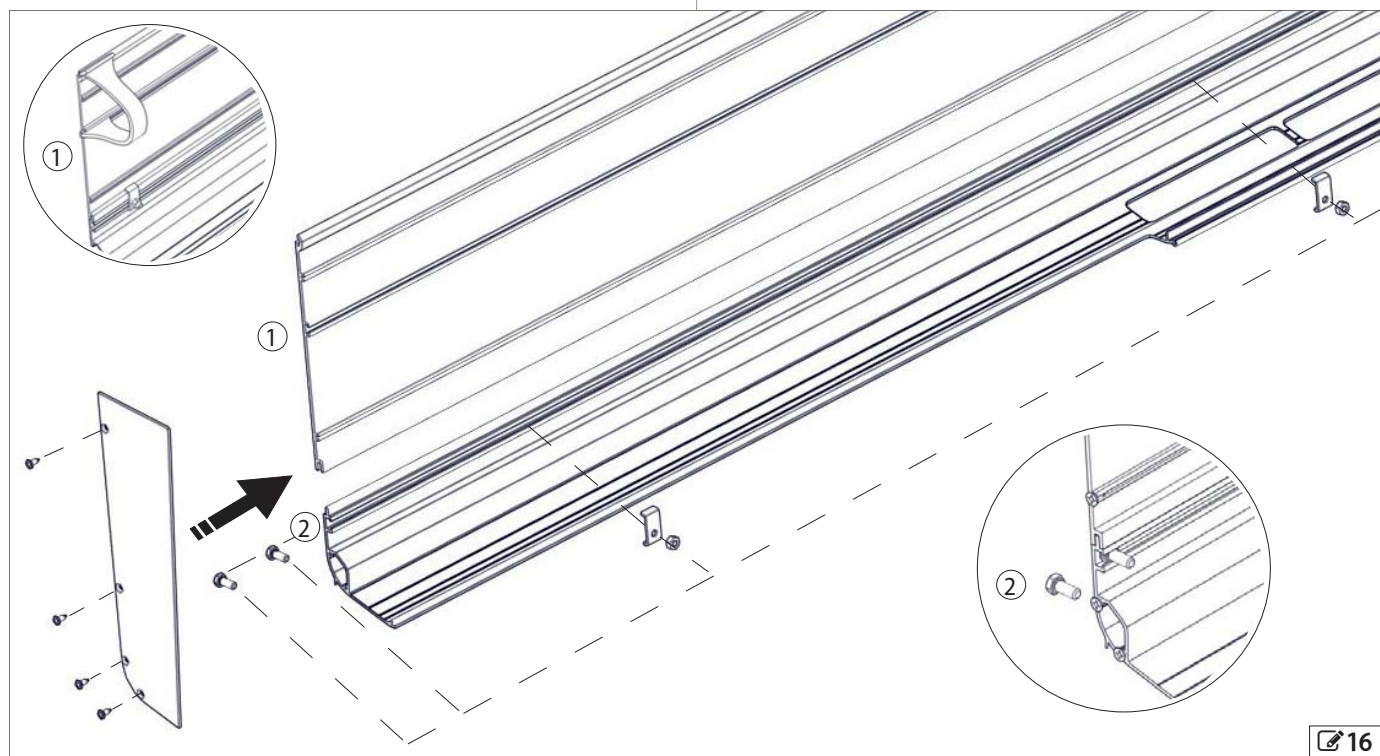



Tighten the screws to the fastening torques specified in

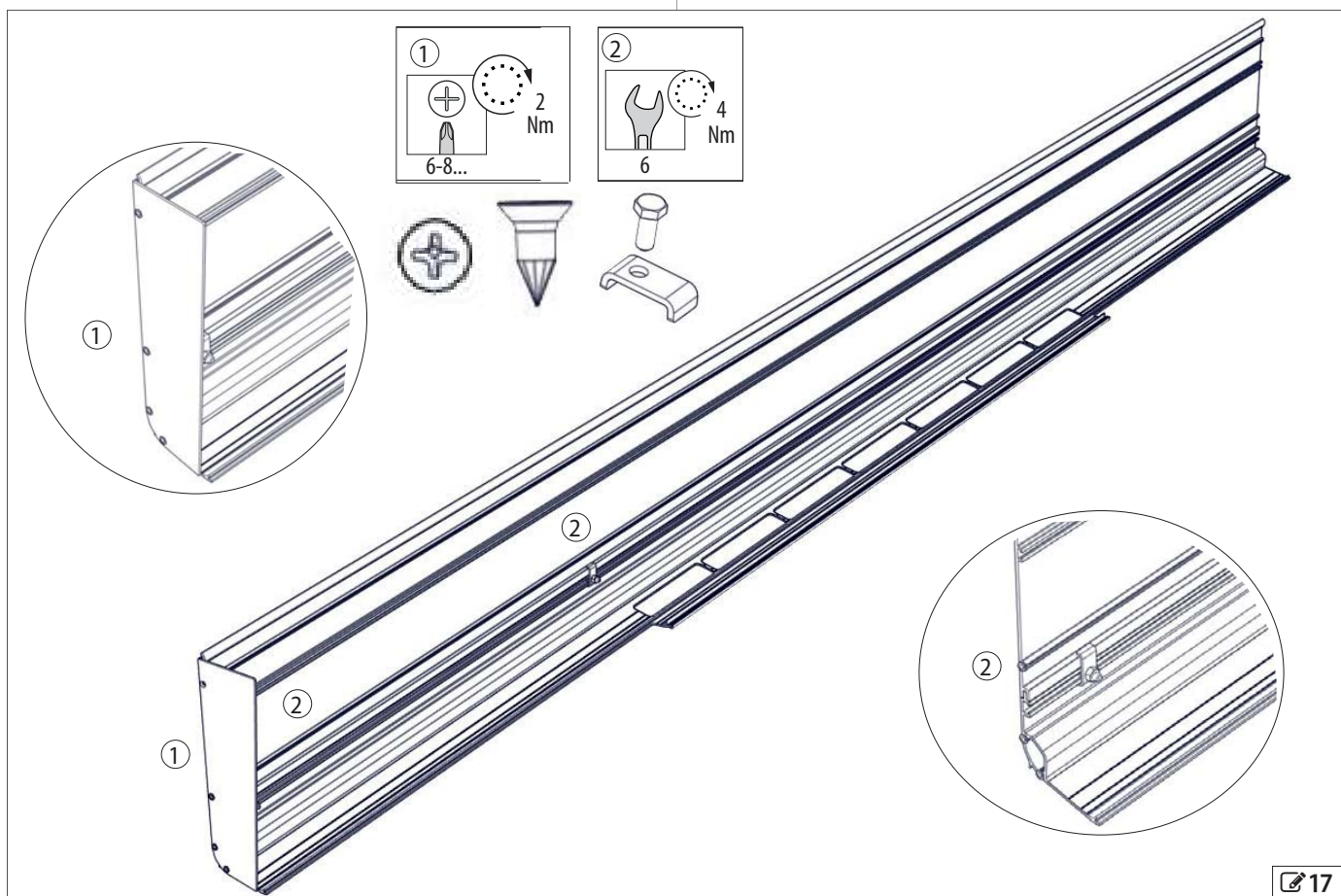

 17-① ② .

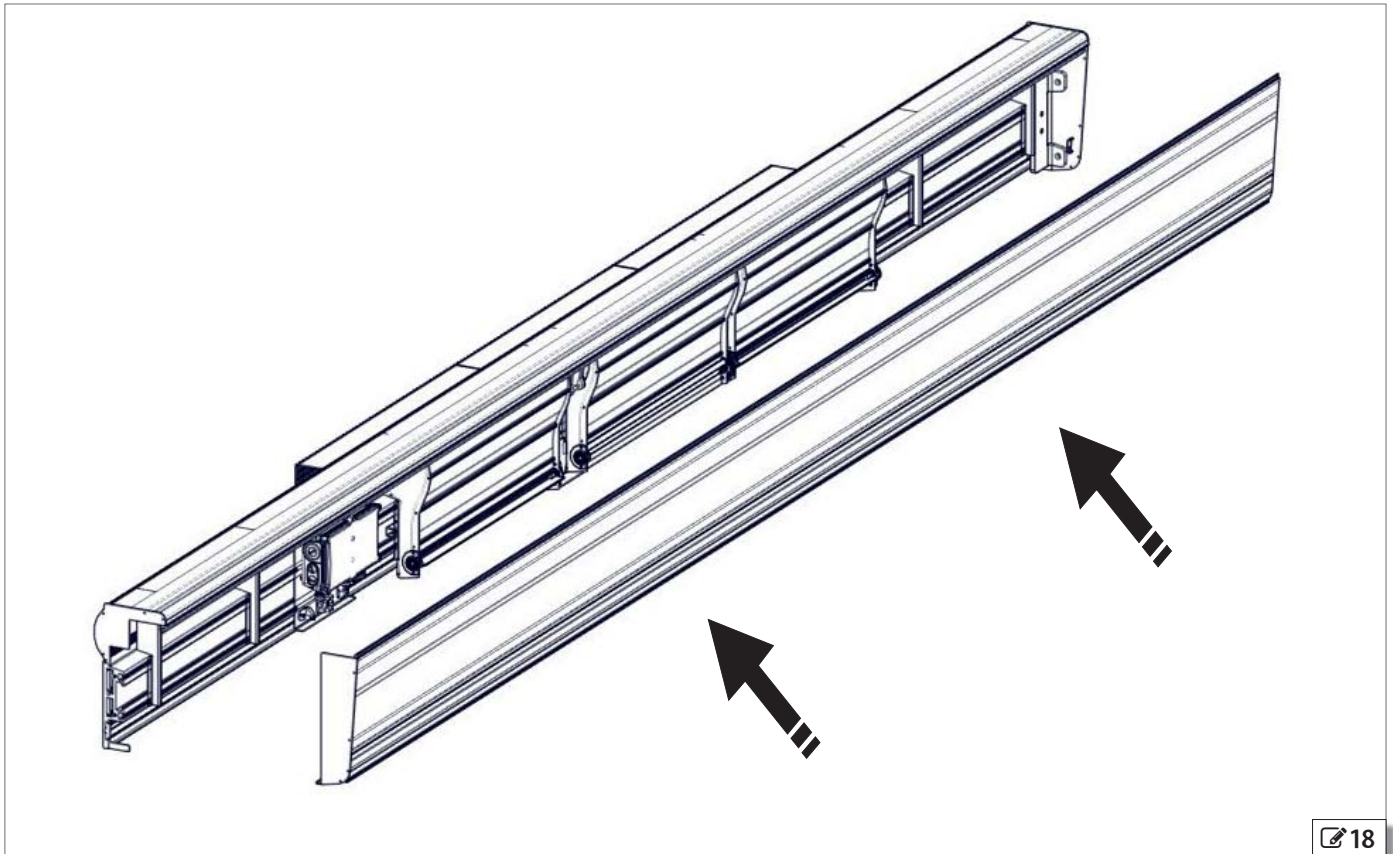

AIRSLIDE casing installation.

Once the casing has been assembled, insert it into the main profile, tilt it and insert it into the upper profile.  18  19.



Then insert the parachute cables between the casing and upper profile in the grooves of the profiles  19  20 ① ②

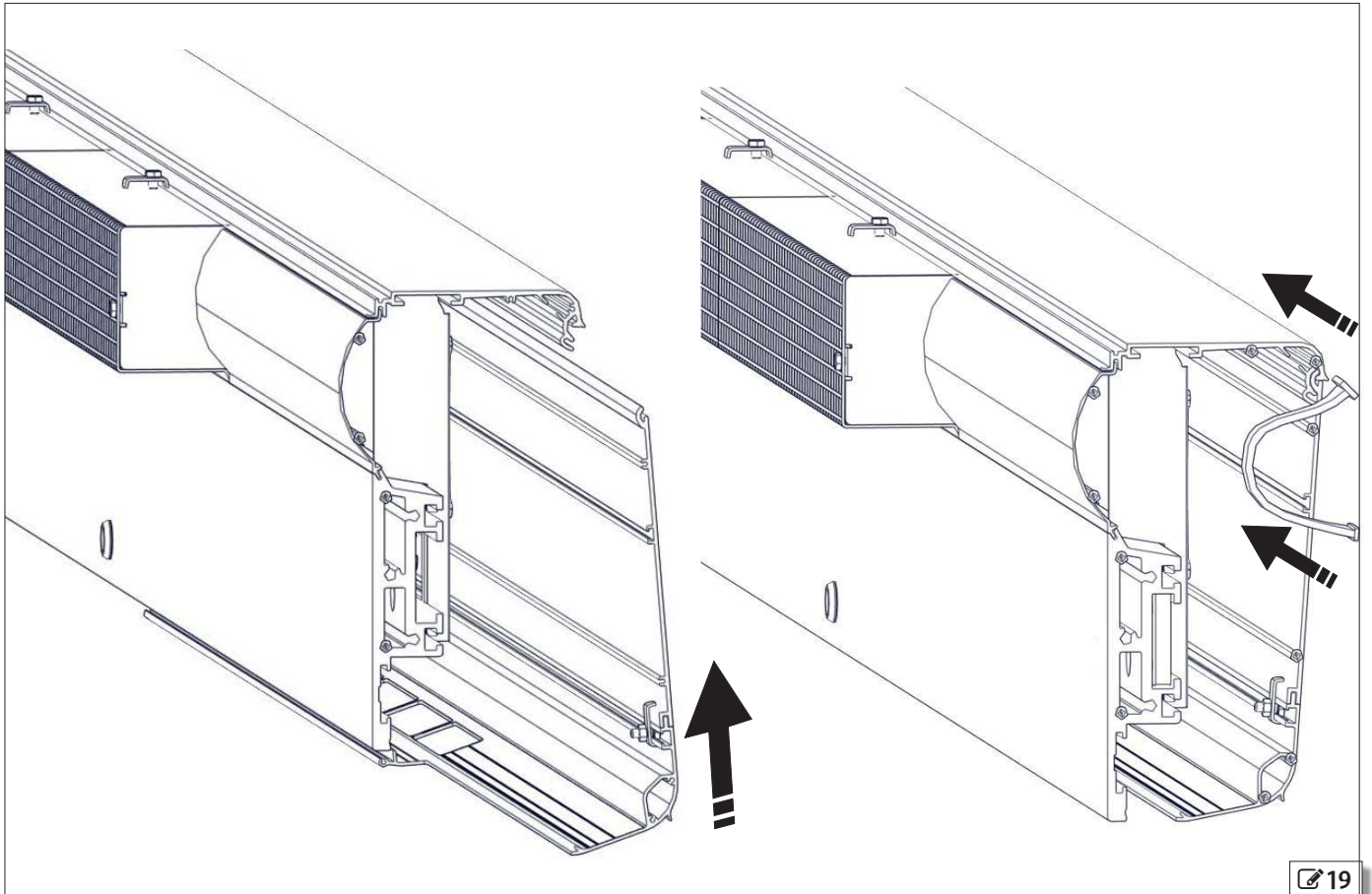

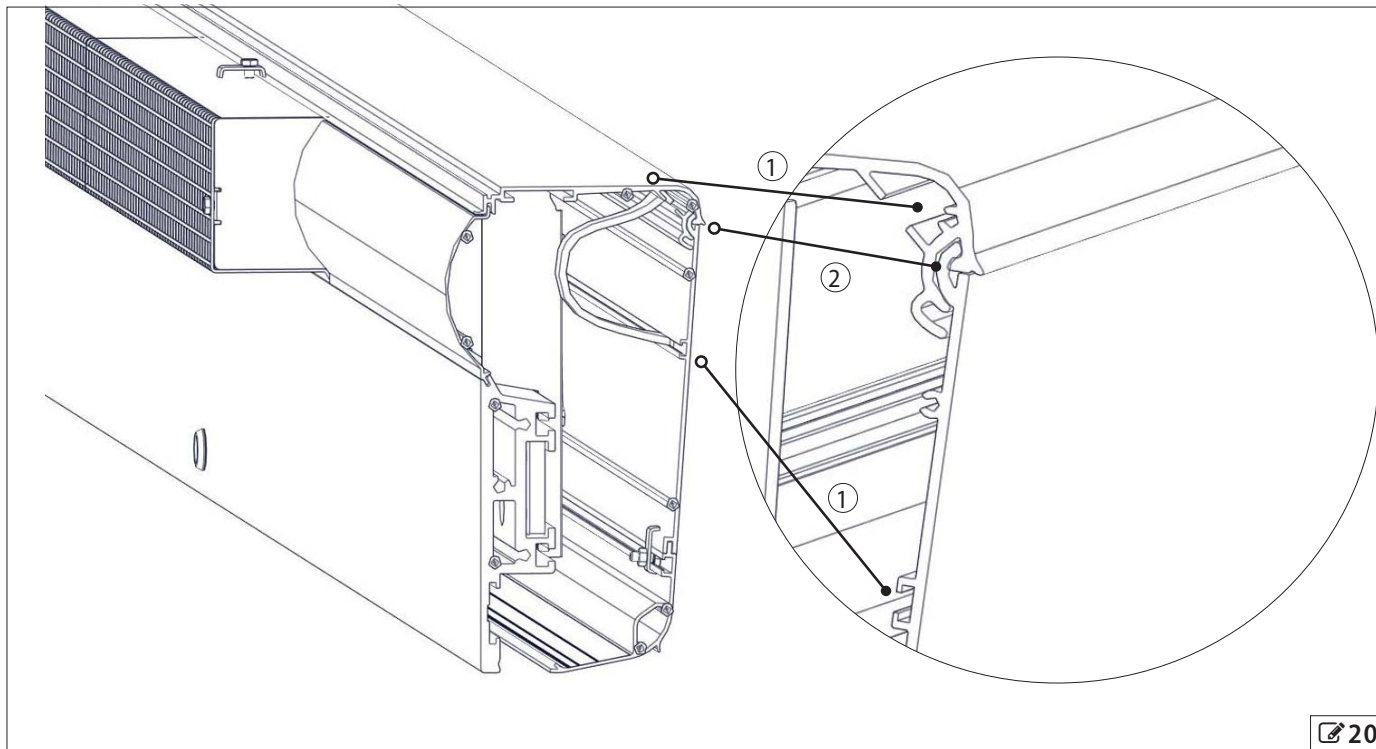

20

Fasten the closing casing using the lock fitted on the main profile.

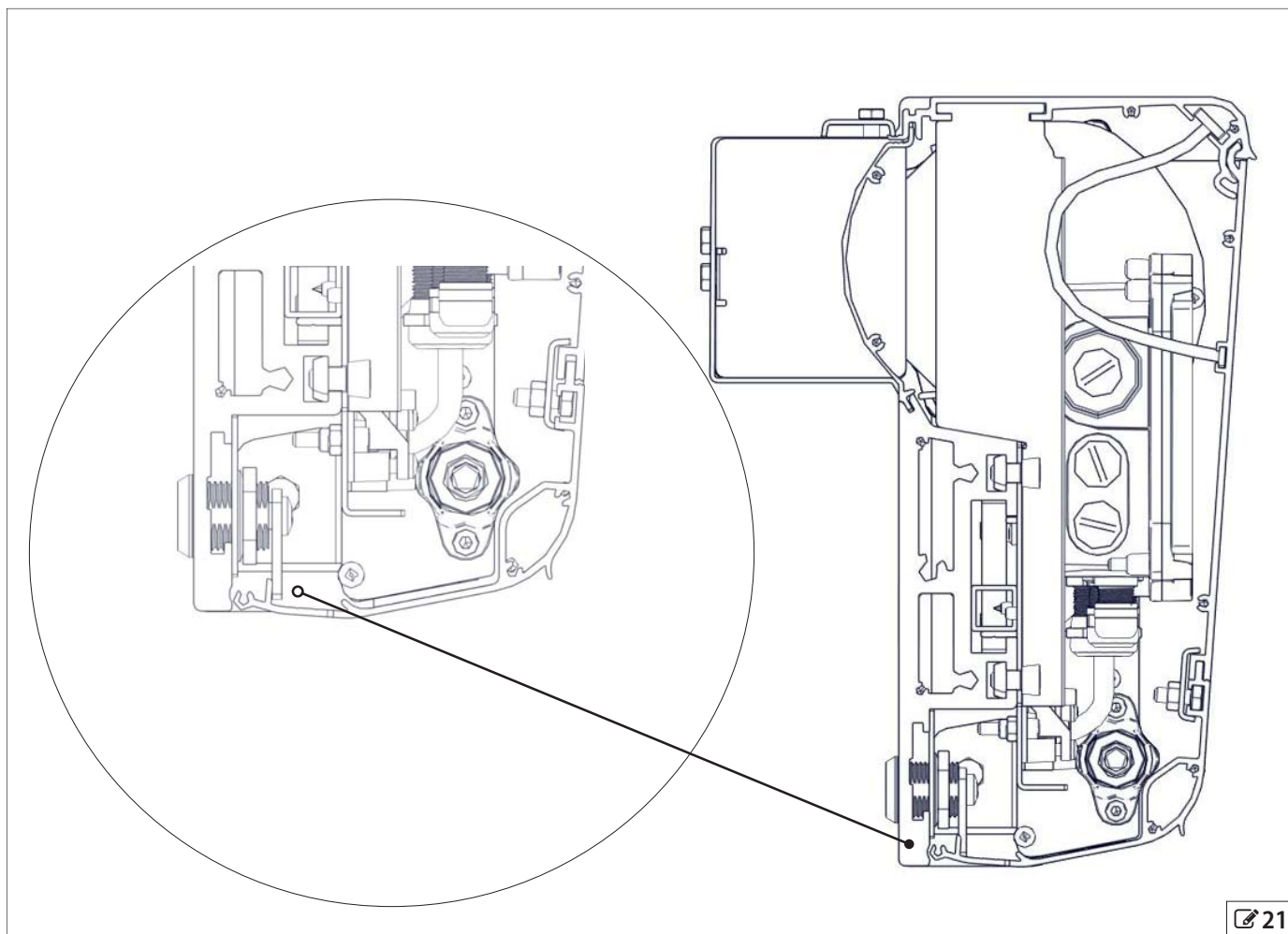

21

Apply the two warning stickers (hazard to hands and fingers), supplied with the electric fan component, to the sides of the intake slots.  22

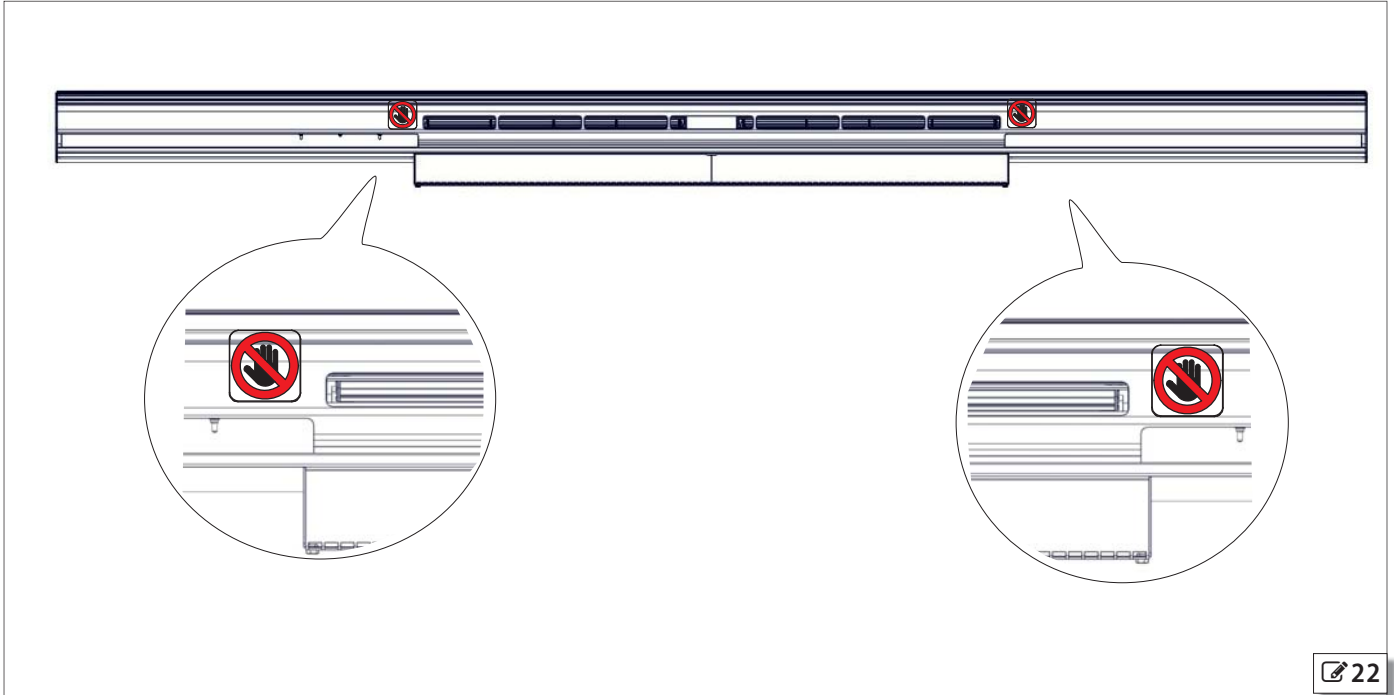

 22

Side Bracket Fastening

For side fastening of AIRSLIDE, use the side bracket to fasten to the main profile. Insert the plate in the profile AIRSLIDE and fasten it to the wall bracket using the screws provided.

Use the fastening torques given in  23.

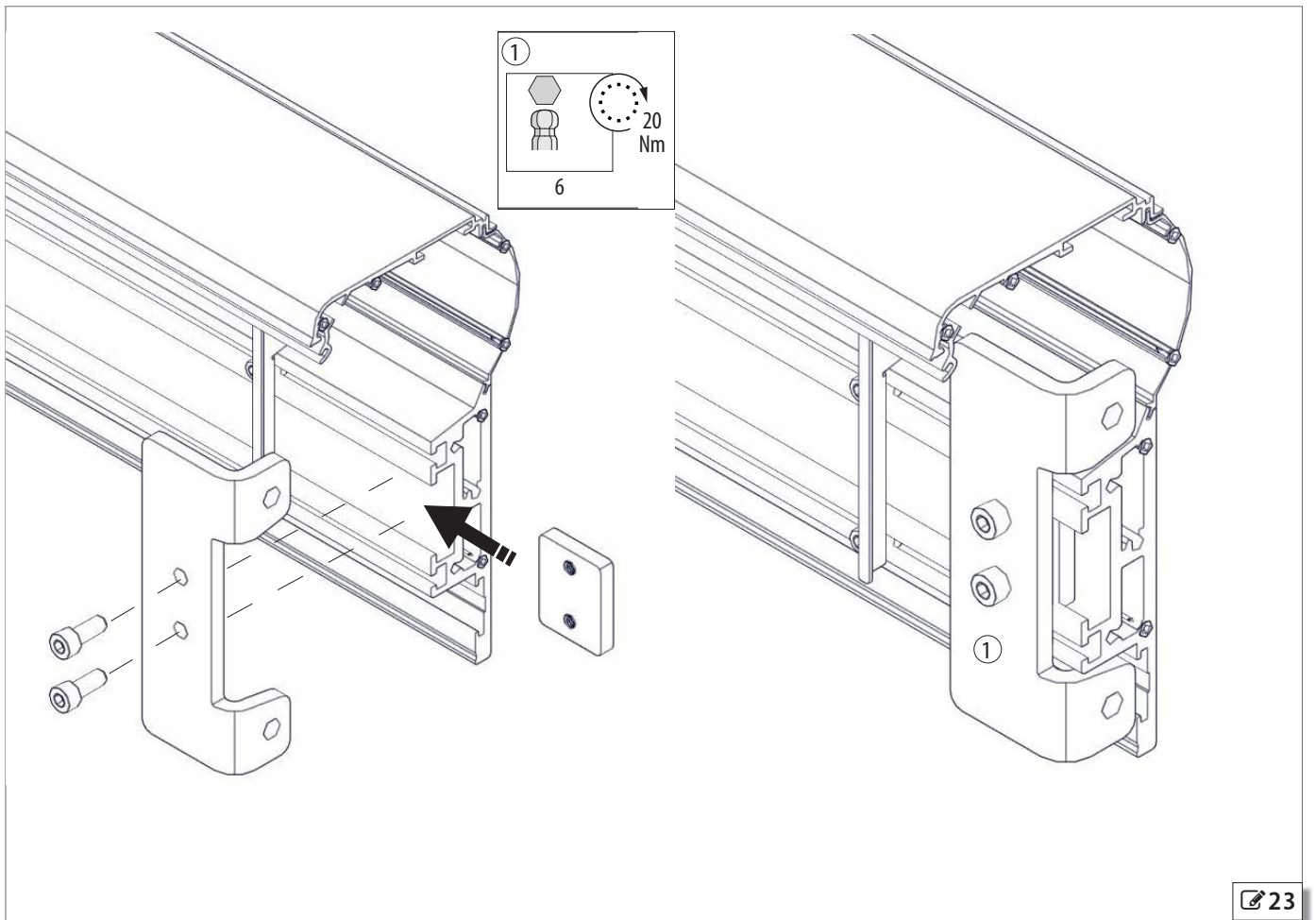

 23

6.2 LOADING AND STRESSES BORNE BY ANCHORS

The support beam is designed for a maximum total system weight of $Q = 326$ kg.

This therefore gives $N = 1.63$ kN for each individual support point

Two different configurations will be analysed; these can be modified in order to achieve a distance between wall edge and upper anchoring which exceeds the minimum requirement (given below):

Configuration 1

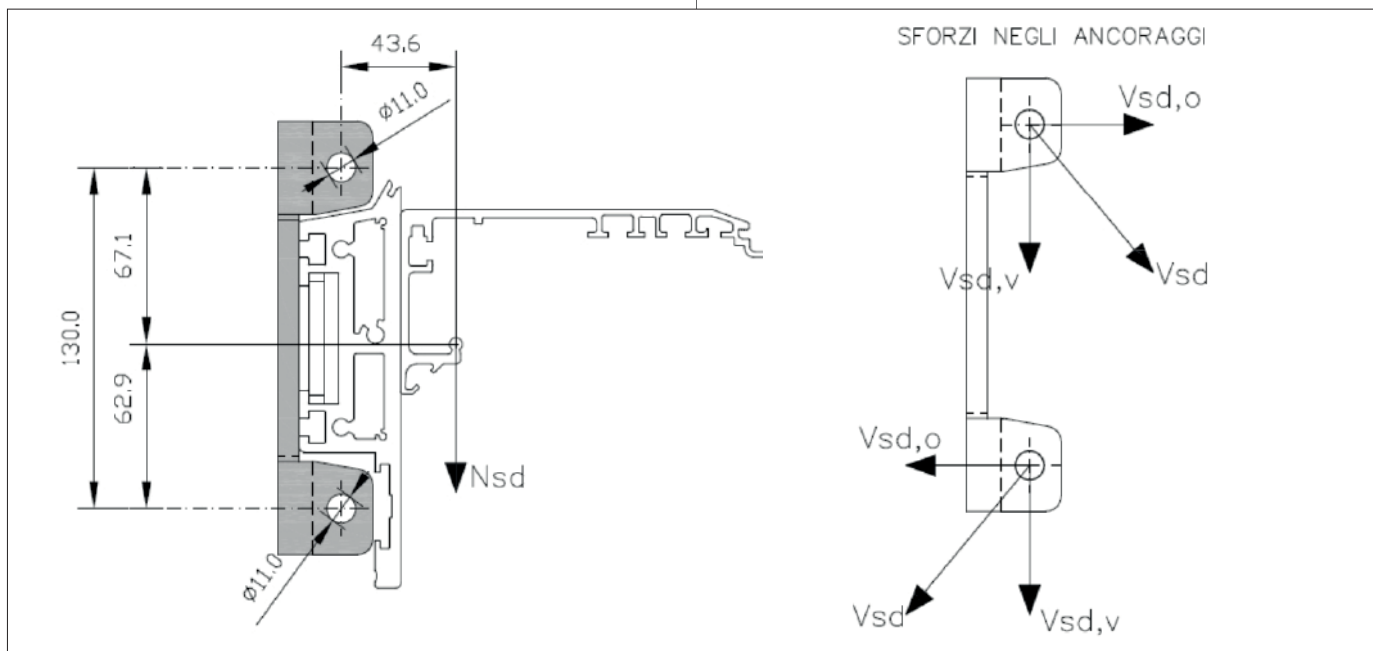

■ Configuration 2

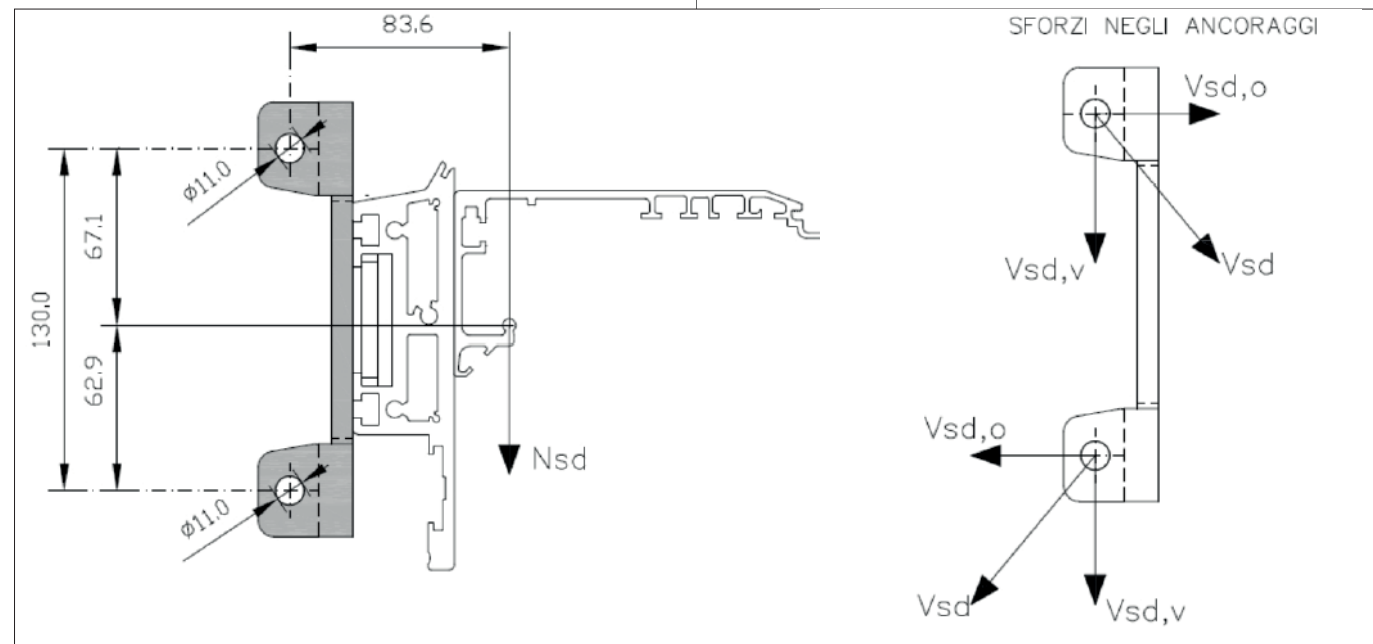

With these configurations, the maximum stresses on the individual anchors (dowels) are:

■ **Design actions**

N= 1.63 kN Reaction to support
 Yg= 1.3 Design partial factor
 Nsd= 2.12 kN Design reaction

■ **Configuration1 _Base data**

d= 130 mm Vertical distance between fasteners
 e= 43.6 mm Eccentricity of load with respect to fastener axes
 Nsd= 2.12 kN Design reaction
 Mt sd=0.092 kNm Couple generated by N x e .

■ **Stresses in anchors**

Vsd,v= 1.06 kN Vertical reaction on individual anchor
 Vsd,o= 0.71 kN Horizontal reaction on individual anchor

Vsd = 1.28 kN Total reaction at anchor

■ **Configuration2 _Base data**

d= 130 mm Vertical distance between fasteners
 e= 83.6 mm Eccentricity of load with respect to fastener axes
 Nsd= 2.12 kN Design reaction
 Mt sd=0.177 kNm Couple generated by N x e .

■ **Stresses in anchors**

Vsd,v= 1.06 kN Vertical reaction on individual anchor
 Vsd,o= 1.36 kN Horizontal reaction on individual anchor

Vsd = 1.73 kN Total reaction at anchor

Configuration 2 is worse in terms of the stresses in the dowels; therefore, if the minimum distances from the edge allow it (see minimum distances from edges Cmin in following sections), it is advisable to use configuration 1.

6.3 PERMISSIBLE SUBSTRATES

The following masonry substrates are permissible for fastening the beam to:

- CONCRETE
- SOLID BRICK (VOIDS < 15%)
- HOLLOW BRICK (15% < VOIDS < 45%)

For other existing substrate types (natural stone, hollow brick with a greater proportion of voids, gypsum board etc.), it will be necessary to prepare a counterframe made from:

- STEEL FRAMEWORK
- ALUMINIUM FRAMEWORK
- WOODEN FRAMEWORK

6.4 SUBSTRATE CONDITION

Before installation, you must carefully check the condition of the existing substrate which the beam is to be attached to; this substrate must be in good condition without any evident cracking or patching up; more specifically, by substrate type, the following requirements apply:

■ **CONCRETE**

The attachment surface must be homogeneous and compact, without voids or flaking due to corrosion caused by carbonation.

■ **SOLID BRICK (VOIDS < 15%)**

The attachment surface must be homogeneous, without any cracking brickwork or evidence of cementitious or gypsum-based plaster or rendering having been applied; the mortar joints must not come away simply by running a hand tool over them, and the wall must have been faced to a good standard.

■ **HOLLOW CONCRETE BLOCKS**

No cracking or other damage should be evident, and they should not have been subject to previous installations; the blocks must have been laid to a good standard using thin-joint techniques or standard mortar joints, following the manufacturer's specifications.

■ **STEEL FRAMEWORK**

Steel counterframes must show no signs of corrosion and must be treated with red oxide primer.

Such counterframes must be specified by the installer in accordance with the loads given, and must in turn be anchored using appropriate hardware to a supporting structure which is able to keep them stable. A minimum thickness of 6mm is recommended for such structures.

■ **ALUMINIUM FRAMEWORK**

The rods of the counterframe must show no sign of deformation, and they must not have been subject to cold bending which could cause micro-cracking or localised weaknesses.

Such counterframes must be specified by the installer in accordance with the loads given, and must in turn be anchored using appropriate hardware to a supporting structure which is able to keep them stable. A minimum thickness of 6mm is recommended for such structures.

When using aluminium counterframes, a layer of teflon must be placed between the framework and the metal beam to prevent galvanic corrosion.

■ **WOODEN FRAMEWORK**

The lumber used must show no sign of rot or damp, and must not have been previously used, cut or damaged.

Such counterframes must be specified by the installer in accordance with the loads given, and must in turn be anchored using appropriate hardware to a supporting structure which is able to keep them stable. A minimum thickness of 30mm is recommended for such structures.

It is always preferable to have the counterframes specifically made to measure, providing for through fasteners (bolts for metal frames, self-tapping screws or similar or else bolts for timber frames).

6.5 MINIMUM ANCHOR DISTANCES FROM EDGES

The following minimum distances from both side edges have been determined after examining the instructions/specifications for some of the most popular dowels on the market:

SUBSTRATE	Cmin (mm)
CONCRETE	40/50
SOLID BRICK (VOIDS < 15%)	100
HOLLOW BRICK (15% < VOIDS < 45%)	100

In the event that it is not possible to comply with the minimum distances specified, a counterframe suitably fastened to the wall must be provided for.

7. ELECTRONIC INSTALLATION

RISKS



PERSONAL PROTECTIVE EQUIPMENT



REQUIRED TOOLS



2.5

7.1 PLATE AND E1AS BOARD

Connect the 230 VAC mains power supply to the terminal on the board plate.



ALWAYS DISCONNECT THE POWER SUPPLY before working on the board. Turn power on only after having made all the electrical connections and carried out the preliminary start-up checks.

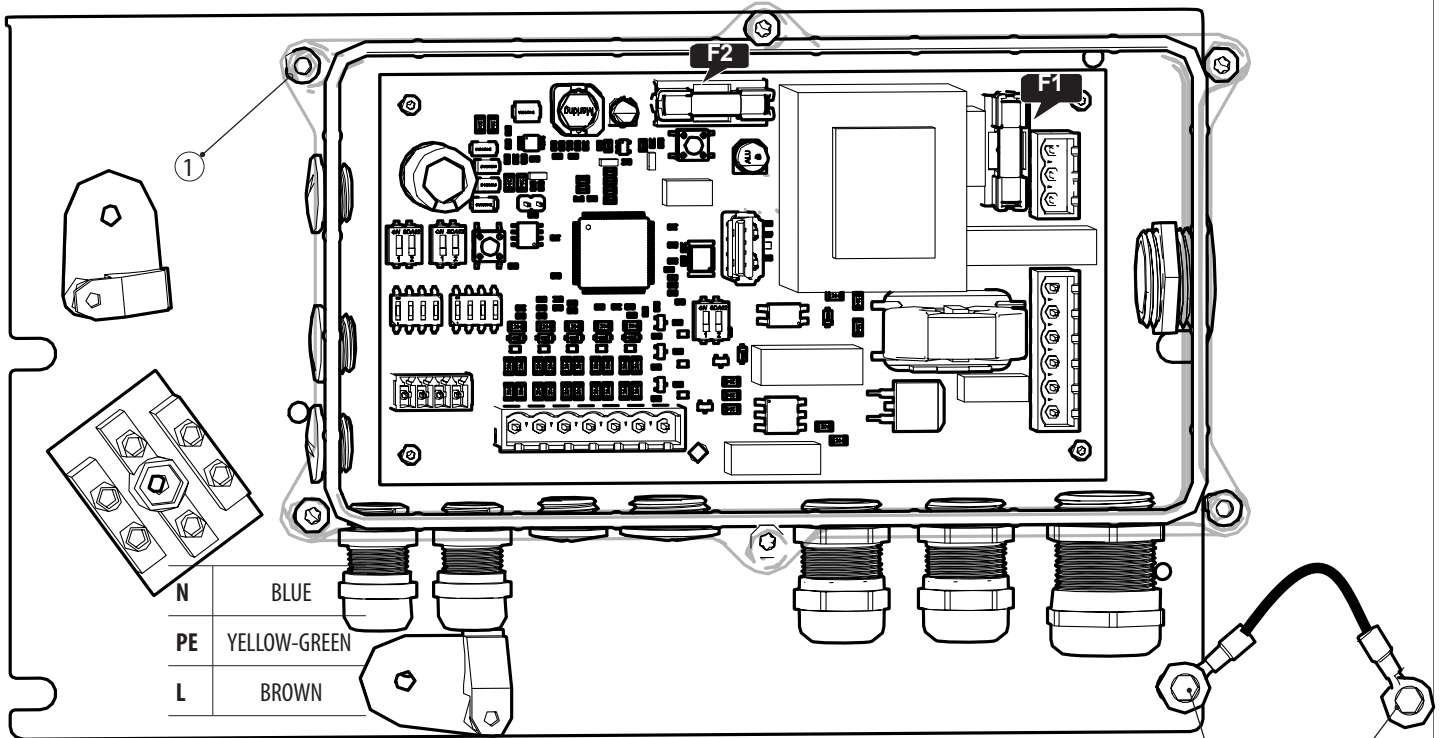

Fuses

F1 230Vac power supply fuse 3.15 A

F2 Secondary power supply fuse 250 mA

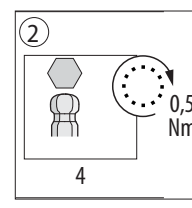
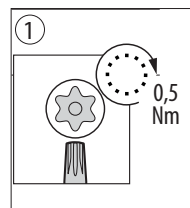

7.2 TERMINAL BOARDS AND CONNECTORS

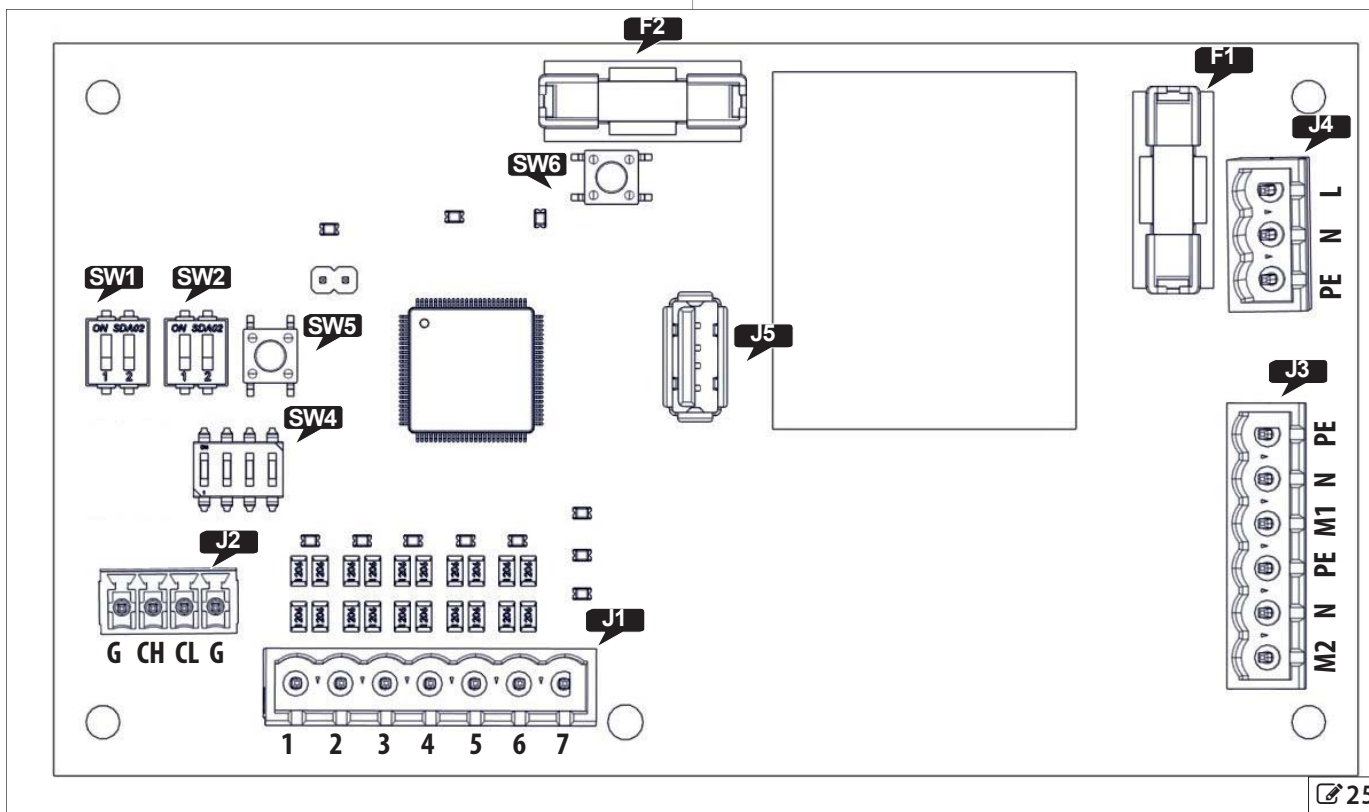

25

■ J1 - INPUTS

1 2 3 4 5 6 7

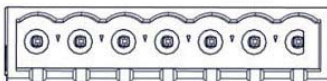

1	Emergency
2	Speed command V1
3	Speed command V2
4	Input1
5	Input2
6	GND
7	GND

■ J2 - INTERCOM



G CH CL G

G	GND Accessories power supply negative and Common contacts
CH	CH CANBUS High Channel
CL	CL CANBUS Low Channel
G	GND Accessories power supply negative and Common contacts

■ J3 - motor INPUTS

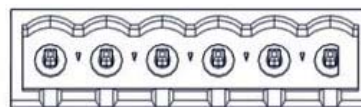

M2 N PE M1 N PE

M2	BROWN Motor 2
N	BLUE Motor 2
PE	YELLOW-GREEN
M1	BROWN Motor 1
N	BLUE Motor 1
PE	YELLOW-GREEN

■ J4 - 230VAC power supply

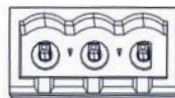

PE N L

PE	YELLOW-GREEN
N	BLUE
L	BROWN

DIP SWITCH SW1 - SW2

- Motor 1 _ Motor 2 speed adjustment

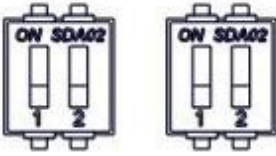

DIP SWITCH SW4

- INTERCOM

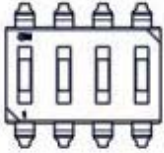

J5 - USB PORT

- EIAS board update



BUTTON SW5

- Motor test



BUTTON SW6

- Board Reset

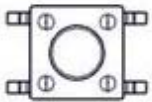

7.3 E1AS ELECTRONIC BOARD LEDS

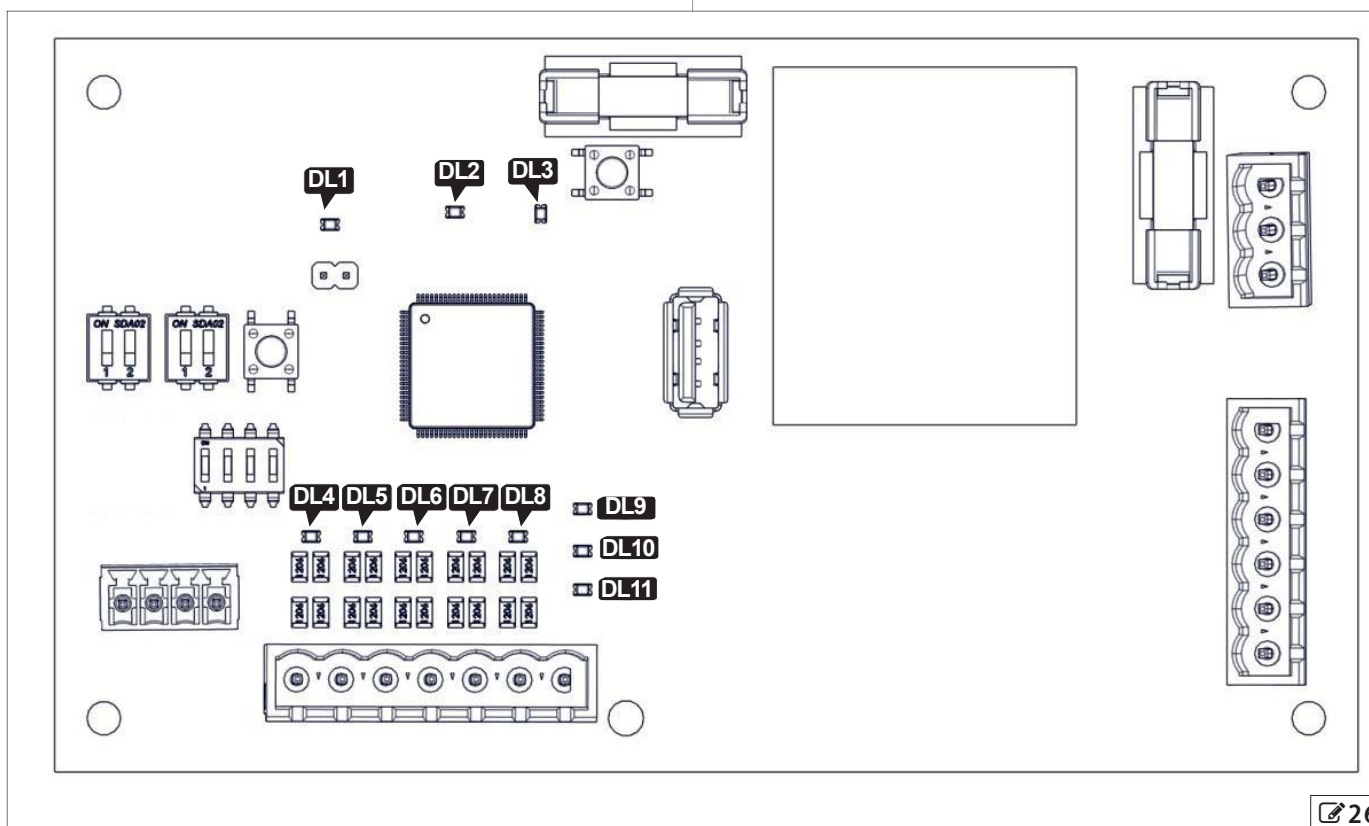

26

8 LEDs on the board

Name	Description	States	input active	input not active
DL1 (BLUE)	+24Vdc			
DL2 (BLUE)	+5Vdc			
DL3 (BLUE)	+3.3Vdc			
DL4 (RED)	Emergency			
DL5 (RED)	Speed1			
DL6 (RED)	Speed2			
DL7 (RED)	I1			
DL8 (RED)	I2			
DL9 (GREEN)	OK board status			
DL10 (RED)	Error			
DL11 (RED)	USB			

LED statuses:

	on		flashing
	off		in sleep mode: off with blinking every 5 s

* = standby condition

7.4 J1 - INPUTS

Manual and automatic controls can be connected to input J1 to manage the 2 AIRSLIDE speeds.

A three-position switch connected between pin2 (V1) and pin3 (V2) and pin6 (GND) allows speeds V1 (low) and speed V2 (high) to be managed.

Using pin 4 (I1) and pin5 (I2) it is possible to manage speeds V1 and V2 automatically.

7.5 J2 INTERCOM

(with E1SL firmware version 3.2 or later)

It is possible to manage the AIRSLIDE speeds via the Intercom connection between board E1AS and board E1SL of the automatic door  27.

Intercom communication occurs by selecting ID addresses on the E1AS board.

The possible addresses are as follows:

E1AS SW4	E1SL (SDK EVO)
9	1
10	2
11	3
12	4
13	5
14	6
15	7



The SW4 ID addresses from 0 to 8 on the E1AS board are not active

■ Description

The E1AS board is able to communicate with other E1AS units via an Intercom network connection and programmed via the E1SL board of the automatic door and the programming unit SDK EVO. This allows the various functions (Programming menu/Intercom/Function) to be performed:



Every network connected E1SL should be programmed for the same Intercom mode.

■ Connection

The network connection of the units uses three wires in a cascade between connectors J18 of the E1SL boards and J2 of the E1AS boards.



The sequence in which the units are wired is unimportant, but it is essential that a CASCADE connection is used.

■ Addressing

A unique node ID must be assigned to each E1AS present in the network (Programming menu/Intercom/MasterSlave_nr) .



Do not assign the same Node ID to more than one unit in the network.

■ Registration

After having wired up and assigned an address to each unit, registration must be carried out (Programming/Intercom/Node registration) only on the Master E1SL that has been assigned Node ID=1.

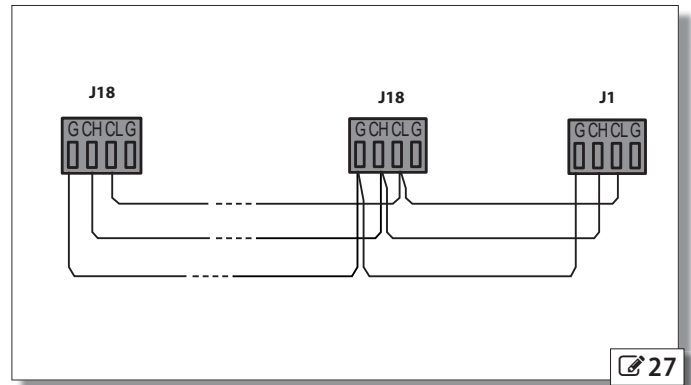

7.6 J7 - MOTOR INPUTS

It is possible to connect 2 motors, M1 and M2, to connector J7. The second motor M2 is connected for electric fan modules with more than three fans.

7.7 J5 - MAINS POWER SUPPLY

The E1AS is powered on connector J5 with 230Vac 50/60Hz mains power. The board automatically recognises the mains voltage frequency.

When the board is switched on, LED DL 3 flashes to indicate that it is operating correctly.

During movement of motor 1 or motor 2, LED DL3 will remain steadily lit.

When movement of motor 1 or motor 2 finishes, LED DL3 will begin to flash again.

7.8 BUTTONS SW5 AND SW6

There are 2 buttons on board E1AS :

1. SW5 Motor test button – Operates the motor at maximum speed when pressed. It has priority over all other inputs.
2. SW6 Board reset button – Pressing this resets the board

7.9 DIP SWITCHES SW1 AND SW2

There are 2 DIP switches on board E1AS :

1. SW1 2-way DIP switch for adjustment of speed 1
 - DIP switch OFF - OFF (High speed)
 - DIP switch ON - OFF (Medium-High speed)
 - DIP switch OFF - ON (Medium-Low speed)
 - DIP switch ON - ON (Low speed)

2. SW2 2-way DIP switch for adjustment of speed 2
 - DIP switch OFF - OFF (High speed)
 - DIP switch ON - OFF (Medium-High speed)
 - DIP switch OFF - ON (Medium-Low speed)
 - DIP switch ON - ON (Low speed)

7.10 DIP SWITCHES SW3 AND SW4

It is possible to assign an ID address on board E1AS communication using DIP switch SW4 on board E1AS.



DIP switch SW3 is not used.

The ID assignment table is given below:

E1AS ID	SW4	E1SL ID (SDK EVO)
9	1001	1
10	1010	2
11	1011	3
12	1100	4
13	1101	5
14	1110	6
15	1111	7

7.11 J8 USB INPUT

USB port for E1AS update.

Insert the USB device on J8.

Press button SW6 (Reset) for USB recognition.

LED DL10 will light up and DL3 will switch off.

Press and hold button SW5 (motor test) for 3 seconds and LED DL10 will flash during the update phase.

When the update is complete, LED DL10 will light up steadily and DL3 will turn on.

Remove the USB device

The name of the file to be loaded on the USB device is:

- E1AS.hex E1AS board firmware



The update files may be downloaded from the website: www.faacgroup.com

The USB device must be formatted with FAT or FAT 32 file system. The NTFS format is not recognised by the control board.

The necessary files must be directly available on the USB storage medium with the precise names defined; they must not be zipped or inside folders.

Use a USB with maximum 500mA absorption.

7.12 E1AS BOARD OPERATION

Board E1AS manages the activation of the electric fan unit via commands received from other boards or from the operator.

The commands can be received via Inputs (J1) or via CAN BUS (J2) 27.

It is also possible to use a single system for the commands.

If both are used, the commands on J1 have priority.

The fan turns on in the conditions specified in table 29.

The fan will be switched off under all other conditions.

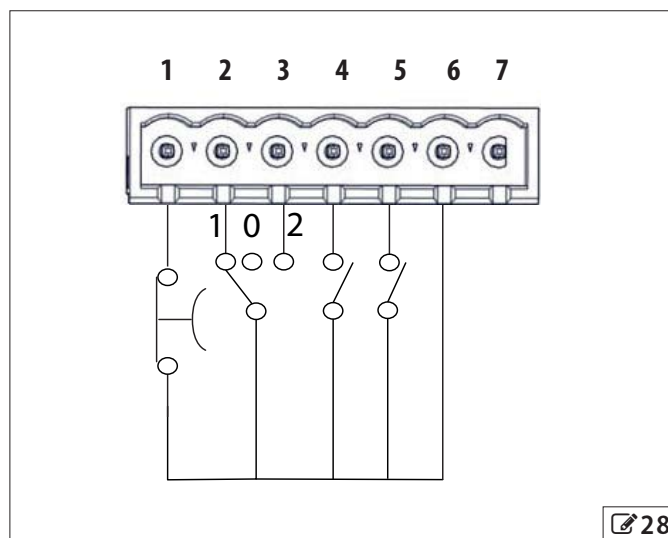

The following is a table with the various configurations connected to the inputs for button P1,P0,P2 and the inputs for management of external commands I1, I2.

The commands from the CanBus are also taken into consideration. The speed column allows speed V1 or V2 to be determined.

The table with the various J1 configurations is given below:
Input configuration table

Emerg	P1	P0	P2	I1	I2	Can ID>9	CanV1	CanV2	Velocità Ventola
Pin1 (J1)	Pin2(J1)	--	Pin3(J1)	Pin4(J1)	Pin5(J1)	--	---	---	
0	0	0	1	1	0	0	0	0	V2
0	0	0	1	1	1	0	0	0	V1
0	0	0	1	1	0	0	0	1	V2
0	0	0	1	1	1	0	0	1	V1
0	0	0	1	1	0	0	1	0	V2
0	0	0	1	1	1	0	1	0	V1
0	0	0	1	1	0	0	1	1	V2
0	0	0	1	1	1	0	1	1	V1
0	1	0	0	1	0	0	0	0	V1
0	1	0	0	1	1	0	0	0	V1
0	1	0	0	1	0	0	0	1	V1
0	1	0	0	1	1	0	0	1	V1
0	1	0	0	1	0	0	1	0	V1
0	1	0	0	1	1	0	1	0	V1
0	1	0	0	1	0	0	1	1	V1
0	1	0	0	1	1	0	1	1	V1
0	0	0	1	0	0	1	1	0	V2
0	0	0	1	0	1	1	1	0	V2
0	0	0	1	1	0	1	1	0	V2
0	0	0	1	1	1	1	1	0	V2
0	0	0	1	0	0	1	1	1	V1
0	0	0	1	0	1	1	1	1	V1
0	0	0	1	1	0	1	1	1	V1
0	0	0	1	1	1	1	1	1	V1
0	1	0	0	0	0	1	1	0	V1
0	1	0	0	0	1	1	1	0	V1
0	1	0	0	1	1	1	1	0	V1
0	1	0	0	0	0	1	1	1	V1
0	1	0	0	0	1	1	1	1	V1
0	1	0	0	1	0	1	1	1	V1
0	1	0	0	1	1	1	1	1	V1

■ Key

- 0 input not active
- 1 input active
- V1 low speed
- V2 high speed
- Emergency
- P0 Position 0 of selector
- P1 Position 1 of selector connected to pin 2 of the terminal board
- P2 Position 2 of selector connected to pin 3 of the terminal board
- I1 Signal from Exxx - I1 connected to pin 4 of terminal board
- I2 Signal from Exxx - I2 connected to pin 5 of terminal board
- Can busID>9 If DIP switch SW4 is used to select an ID address > 9, commands are accepted from Can bus
- CanV1 Command from Can bus
- CanV2 Command from Can bus

7.13 INPUT J1 WIRING CONFIGURATIONS

Pin 1 (Emergency) is connected to pin 6 (GND).

No other connection is present.

A three-position switch is supplied with the AIRSLIDE air curtain to control the fan connected to connector J1.

A three-position switch connected between pin 2 and pin 3 can be used to manage speeds V1 and V2 and to pin 6 GND.

Pin 2 corresponds to speed V1 selected via the DIP switch SW2 .

Pin 3 corresponds to speed V2 selected via the DIP switch SW1 .

Speed V2 can also be managed automatically via pin4 and pin5.

To use this in the event that the three-way selector is also used, it must be connected to pin3 (V2).

Connect pin4 to pin6 GND.

■ Configuration 1

Wiring of the three-way switch, with indications of where it is possible to manage the two speeds V1 and V2 as programmed by the DIP switches SW1 and SW2  30:

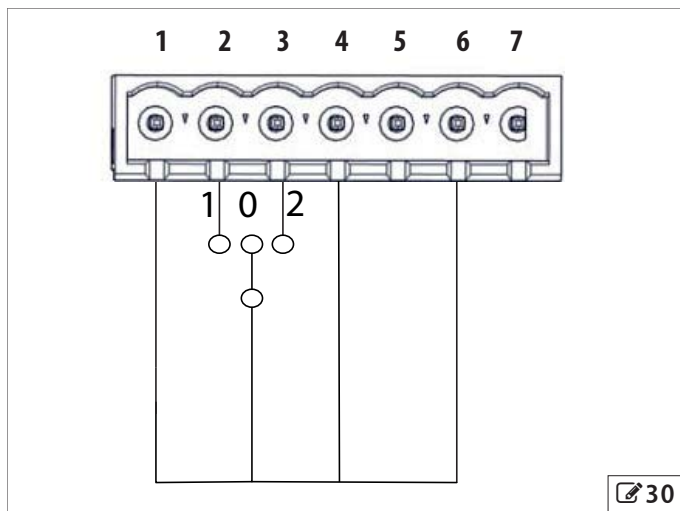

 30

■ Configuration 2

In the event that the three-way switch is not used and automatic speed management is used via inputs I1 and I2.

These inputs are NO (normally open) and manage speed V2.

When these inputs I1 and I2 close,

the speed of the fan moves from speed V2 to speed V1.

In this configuration, connect pin3 to pin6.  31

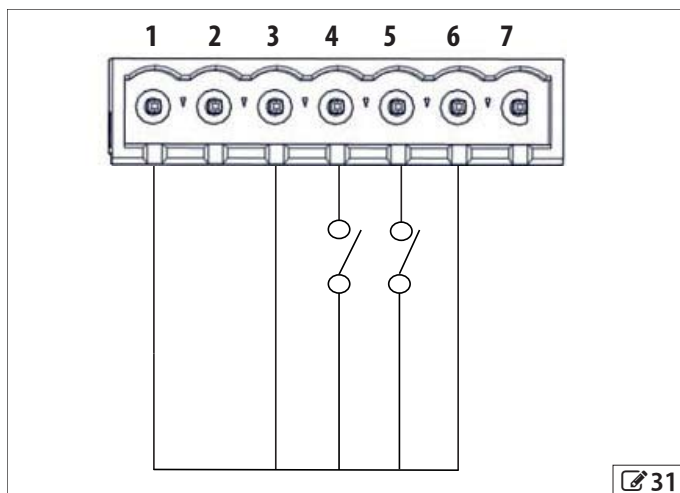

 31

Management of the inputs can be via the automatic door board using outputs O1 and O2.

Example of connection between board E1SL and board E1AS

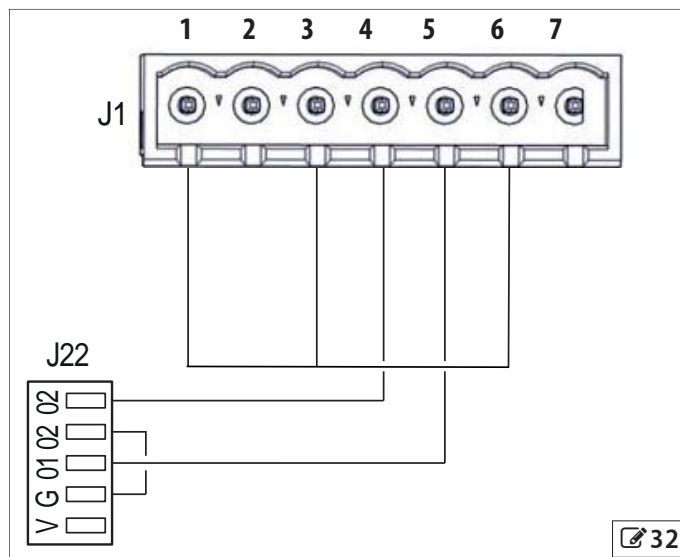

 32

O1 must be programmed on the E1SL board with the parameter 6=Door not closed and O2 with the parameter 11 = At least one safe closing device active.

When input O1 switches from NO (normally open) to NC (normally closed) the selected speed V2 will be activated.

When input O2 switches from NO (normally open) to NC (normally closed) the selected speed V1 will be activated.

speed V1 will remain active as long as the safety device is engaged.

When this condition is no longer present, the the fan will return to speed V2.

Connect pin3 to pin6 GND.  32

■ Configuration 3

This configuration provides for the three-way switch to be connected to pin 2 and pin 3.

An NC button on pin 1 is used to manage an emergency command to lock operation of the AIRSLIDE air curtain in NO (normally open) configuration.

Two NO contacts on pin 4 and pin 5 to manage the speed of the fan via external commands.  33

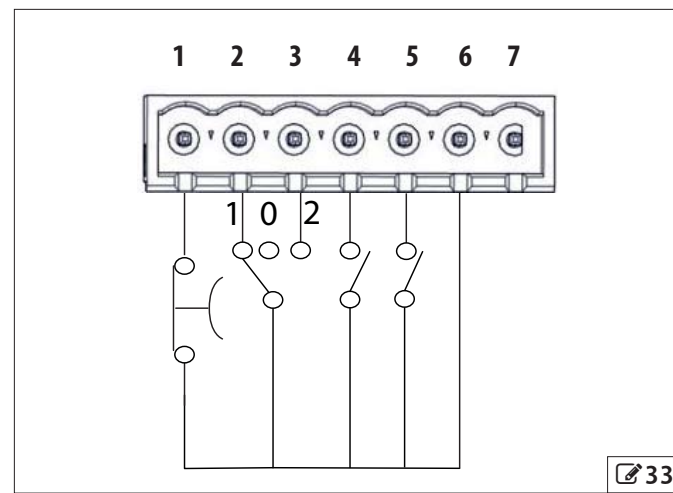

 33

7.14 3 POSITION SWITCH

The 3 position switch is supplied with a 3-wire cable with faston connector and free wires at the other end.

- In position 0 there is no contact between white, brown and green.
- In position 1 there is a NC contact between white and brown.
- In position 2 there is a NC contact between white and green.

The switch is connected to connector J1 as shown in  34 .

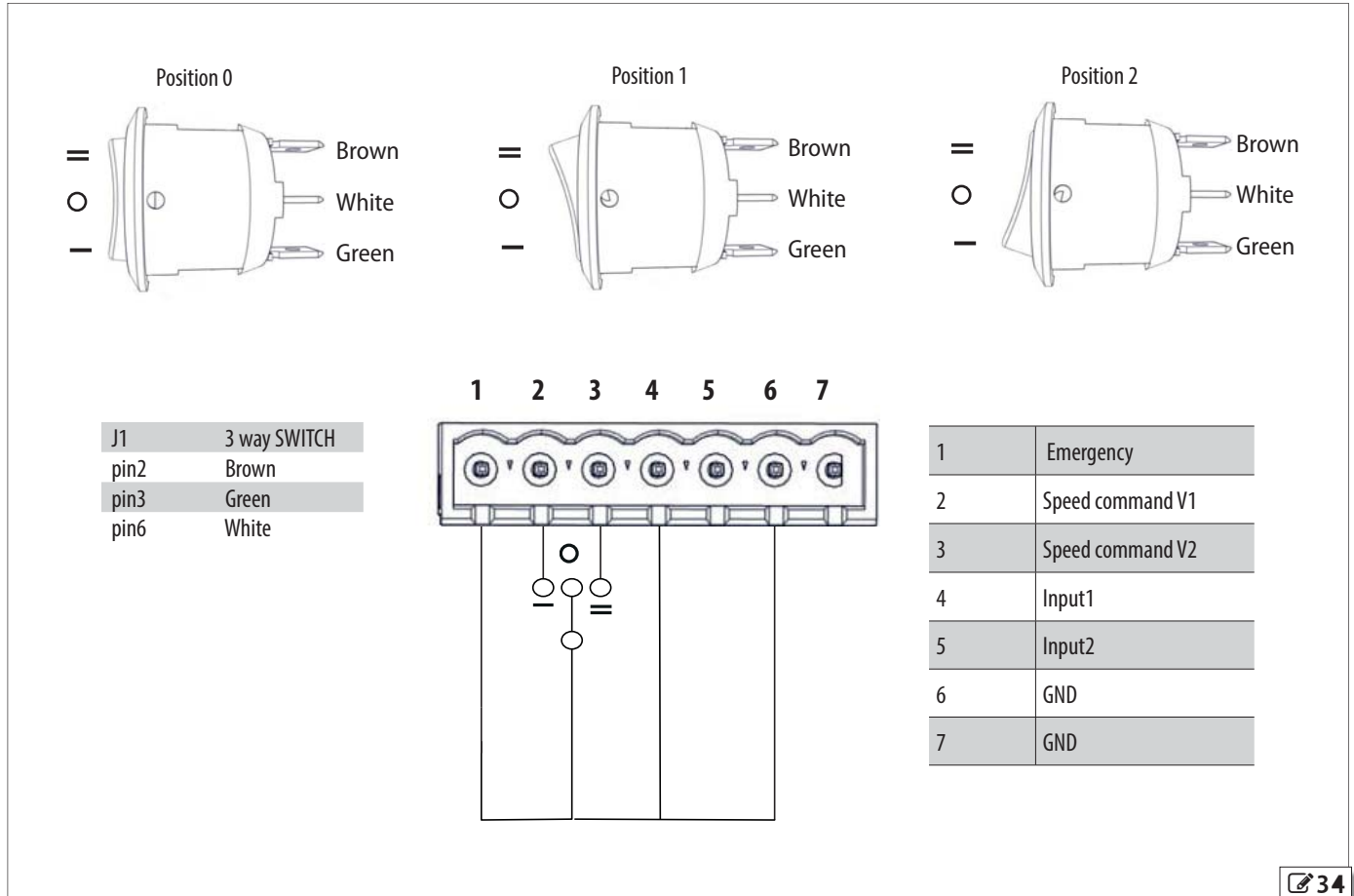



FAAC S.p.A. Soc. Unipersonale
Via Calari, 10 - 40069 Zola Predosa BOLOGNA - ITALY
Tel. +39 051 61724 - Fax +39 051 758518
www.faac.it - www.faacgroup.com